

An Investigation of a Nonlinear Fuel Oil Viscosity and Temperature Control System for Ships

Zhuohang Ye¹, Xiaobing Mao¹, Hai Huang¹ and Xianzhen Liu²

¹Wuhan University of Technology, School of Energy and Power Engineering, 430063 Wuhan, China

²Qingdao Harbour Vocational & Technical College, Department of Marine Engineering, 266404 Qingdao, China

Abstract. In this paper, the differential equation of the fuel oil viscosity and temperature control system was derived, according to the working processes and principles of the heating of heavy oil in ocean vessels. By analyzing the characteristics of the heat transfer model, a multi-input coupling nonlinear heat transfer model was developed, in which the temperatures at the inlet and the outlet of the heavy oil heater were used as the state variables, while the openings of the regulating valve of the mixed oil tank and the steam flow rate regulating valve of the heater were used as the control inputs. This model can be decomposed into a single-input nonlinear system and single-input second-order linear system for further investigation, and the sliding mode variable structure controller can then be solved by performing linear reductions on the nonlinear model. Finally, using KING VIKW software, experiments were performed in order to examine the controlling performances of the PID and sliding mode variable structure (SMVS) controller respectively. The results show that the sliding mode variable structure controller exhibits a series of superiorities, which mainly include a small overshoot, fast response and strong anti-interference capability.

1 Introduction

Currently, VAF, NAKAKITA, VICOCHIEF and FCM manufactured by the ALFA LAVAL Corporation are four common types of ship fuel viscosity control systems. To be specific, VAF, which is a pneumatic viscosity control system, mainly consists of a viscosity meter, differential pressure transmitter, pneumatic controller and control valve, in which the pneumatic controller generally adopts a PI control mode [1]. NAKAKITA is a type of electric viscosity control system with contacts. Owing to the addition of a programmed temperature control to VAF, heating too quickly at a low oil temperature can be avoided effectively by viscosity control, and the operating conditions of the fuel injection equipment can be greatly improved. A pneumatic regulator with a PID control is also used in the NAKAKITA fuel oil viscosity control system [2]. In terms of structure and operating principles, VICOCHIEF is fundamentally different from the commonly-used VAF and NAKAKITA fuel oil viscosity control systems, in which both the viscosity sensor EVT-10C and the controller VCU-160 use single chip microcomputers to replace conventional transmitters and regulators [3].

2 A mathematical model of the fuel oil viscosity and temperature control system

Fuel Conditioning Module (FCM), the fuel supply unit, manufactured by the ALFA LAVAL Corporation is a new generation of ship fuel supply and automatic control system that was specially designed for the automatic monitoring of fuel systems and control of fuel viscosity. Some core devices include the viscosity sensor (EVT-20), the temperature sensor (PT100), the controller (EPC-50B), the steam regulating valve and the fuel heater, among which both the EVT-200 viscosity sensor and the EPC-50B controller use microcomputers to replace conventional transmitters and regulators. Moreover, in contrast to the VICOCHIEF control system, the remote operation panel (OP) is an optional unit in the FCM, which can display the related state and measurement results and can act as a remote control function. Different optional modules are used for realizing different remote control modes including the extensible control, advanced extensible and full-automatic control.

2.1 The working principles of the fuel oil viscosity and temperature control system

From the starting up to the normal operation of the main engine, the fuel oil viscosity and temperature control system for ocean vessels obeys the following procedures: the programmed temperature control of light diesel oil; the fixed temperature control from light diesel oil to heavy oil; the programmed temperature control of heavy oil; and the fixed temperature and viscosity control of heavy oil under the main engine's normal operating conditions. The most important procedure is to maintain a

reasonable temperature and viscosity of heavy oil under normal operating conditions, i.e., the fixed temperature and viscosity control of heavy oil. According to the measured viscosity and temperature relation curves of different types of heavy diesels, the fuel viscosity and temperature exhibit a one-to-one logarithmic relation or can be simplified as a linear mathematical relationship [4]. Therefore, for simplicity, in the current ship fuel oil viscosity and temperature control systems the viscosity of heavy oil is generally set as the temperature that corresponds with the favorable atomization and combustion characteristics of the main engine. When a disturbance occurs in the main engine, both the temperature and viscosity deviate from the given values, and then the temperature should be maintained at a given value and the viscosity should be monitored so as to achieve a fluctuation within a certain range.

2.2 A heat transfer model of the fuel oil viscosity and temperature control system

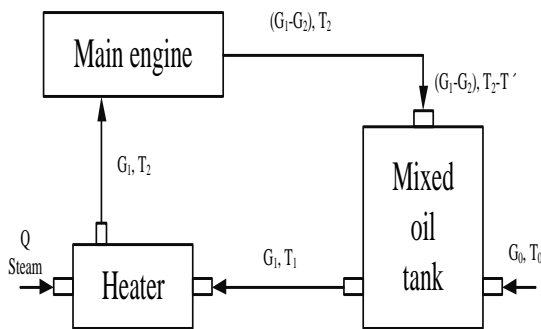

Fig. 1. The working procedures of the fuel oil viscosity and temperature control system.

Figure 1 displays the working procedures of the fuel oil viscosity and temperature control system. Specifically: G_2 denotes the flow rate of the main engine in unit time under a certain load (i.e., the fuel injection rate or fuel combustion rate, with a unit of kg/h); G_1 denotes the flow rate of fuel oil when it flows out from the heat exchanger to the main engine (with a unit of kg/h); G_0 denotes the flow of cool fuel within an initial temperature when it flows into the mixed oil tank (with a unit of kg/h); Q denotes the steam flow rate entering the heat exchanger (with a unit of kg/h); T_1 denotes the temperature of heavy oil when it flows from the mixed oil tank to the heat exchanger (with a unit of °C); T_2 denotes the temperature of heavy oil when it flows from the heat exchanger to the main engine (with a unit of °C); T' denotes the decline in temperature induced by any energy loss in the pipes before the returning oil of the main engine enters the mixed oil tank (with a unit of °C); and T_0 denotes the temperature of heavy oil when it enters the mixed oil tank (with a unit of °C) and is generally set as 70 °C.

The cool oil with an initial temperature of T_0 then enters the mixed oil tank at a flow rate of G_0 , and meanwhile, the hot oil with a temperature of T_2 , which

has not been consumed in the main engine, enters the mixed oil tank at a flow rate of $(G_1 - G_2)$; next, the mixed oil with a temperature of T_1 flows into the heat exchanger at a flow rate of G_1 . Since the fuel oil temperature was far below the preset output temperature, it can be heated by the steam, flow out from the heater at a flow rate of G_1 and a temperature of T_2 , and finally flow into the main engine. Under a varying load, the main engine can consume the hot fuel at a flow rate of G_2 , while the residual oil reflows to the mixed oil tank [5]. By neglecting the external heat loss of the heat exchanger and heat change of the steam, the related mathematical model can be established as:

$$\begin{cases} cM_2 \frac{dT_1}{dt} = c(G_1 - G_2)(T_2 - T') + cG_0T_0 - cG_1T_1 \\ cM_1 \frac{dT_2}{dt} = Q\lambda - cG_1(T_2 - T_1) \end{cases} \quad (1)$$

where: c denotes the specific heat capacity of heavy oil, with a unit of kJ/(kg·°C); M_1 denotes the mass of heavy oil in the heater, with a unit of kg; M_2 denotes the mass of heavy oil in the mixed oil tank, with a unit of kg; and λ denotes the latent heat of the vaporization of steam, with a unit of kcal/kg.

3 The design of the sliding mode variable structure controller

At present, the PID control method is a mainstream method in the vast majority of fuel oil viscosity and temperature control systems for ocean vessels [6]. In spite of its simple structure and the fact that there is no need for an accurate mathematical model of the object, it is fairly difficult to select the proportional band, integral time and derivative time of the regulator using trial-and-error and empirical methods. This study established an accurate nonlinear mathematical model of the system and adopted sliding mode variable structure control algorithms. The variable structure control is a practical and comprehensive method for nonlinear control systems. The sliding mode variable structure is a type of control strategy for variable structure control systems, the basic idea of which is described below. The system first arrives at a certain switching surface, then moves in a sliding mode in the subspace and finally approaches the origin asymptotically [7].

3.1 An analysis of the characteristics of the established mathematical model of the fuel oil viscosity and temperature control system

The related parameters of a ship fuel oil viscosity and temperature control system are set as follows. The specific heat capacity of heavy oil is 1.8 kJ/(kg·°C) (i.e., $c=1.8\text{kJ}/(\text{kg}\cdot^\circ\text{C})$); the latent heat of vaporization is 320 kcal/kg ($\lambda=320\text{kcal}/\text{kg}$); the mass flow rate of heavy oil when it flows into the heater is 205 kg/h ($G_1=205\text{kg}/\text{h}$);

the flow rate of steam entering the heater is 214 kg/h ($Q=214\text{kg/h}$); and the masses of heavy oil in the heater and the mixed oil tank are 12300 kg and 42525 kg ($M_1=12300\text{kg}$ and $M_2=42525\text{kg}$) respectively. In addition, the reflowing of heavy oil from the main engine to the mixed oil tank is connected with heat loss in the pipe, the temperature of heavy oil and ambient temperature (t_0), whose relationship can be approximately written as: $T'=0.0667(T_2-t_0)$. Therefore, equation (1) can be written as:

$$\begin{cases} cM_2 \frac{dT_1}{dt} = -cG_1T_1 + 0.9333cG_1T_2 + 0.0667t_0 + (cT_0 - 0.9333cT_2)u_1 \\ cM_1 \frac{dT_2}{dt} = cG_1T_1 - cG_1T_2 + \lambda u_2 \end{cases} \quad (2)$$

where the flow rate of heavy oil entering the mixed oil tank and the flow rate of steam flowing into the heater, denoted as G_0 and Q , are used as the control input u_1 and u_2 . The oil consumed by the main engine, denoted as G_2 , is approximately equal to G_0 .

Equation (2) describes a multi-input nonlinear system that includes two intercoupled state variables T_1 and T_2 , as well as two control input variables. By selecting the appropriate state variables $x_1 = \int_0^t e_1 dt$, $x_2 = e_1 = T_{10} - T_1$, $x_3 = \int_0^t e_2 dt$ and $x_4 = e_2 = T_{20} - T_2$ (in which T_{10} denotes the preset temperature of heavy oil flowing out from the mixed oil tank and T_{20} denotes the preset temperature of heavy oil flowing into the heater), the equation of state of the fuel oil viscosity and temperature system can be decomposed into two single-input systems:

$$\begin{cases} \dot{x}_1 = x_2 \\ \dot{x}_2 = \alpha(\mathbf{x}) + \beta(\mathbf{x})u_1 \end{cases} \quad (3)$$

$$\begin{cases} \dot{x}_3 = x_4 \\ \dot{x}_4 = -\frac{G_1}{M_1}T_1 + \frac{G_1}{M_1}T_2 - \frac{\lambda}{cM_1}u_2 \end{cases} \quad (4)$$

Equation (3) represents a typical second-order single-input nonlinear system, in which

$$\alpha(\mathbf{x}) = \frac{G_1}{M_2}T_1 - \frac{0.9333G_1}{M_2}T_2 - \frac{0.0667t_0}{cM_2} \quad (5)$$

$$\beta(\mathbf{x}) = \frac{0.9333T_2 - T_0}{M_2} \quad (6)$$

Equation (4) is a simple second-order linear system. For the convenience of programming, T_1 and T_2 , rather than x_2 and x_4 , are state variables in equations (3) and (4).

3.2 The solution of the mixed oil tank regulating valve's control input

For the nonlinear system of equation (3), the following linear reductive transformations can be made:

$$\begin{aligned} \dot{\mathbf{x}} &= \begin{bmatrix} \mathbf{A}_1\mathbf{x} \\ \alpha(\mathbf{x}) \end{bmatrix} + \begin{bmatrix} \mathbf{0} \\ \beta(\mathbf{x}) \end{bmatrix} u \\ &= \begin{bmatrix} \mathbf{A}_1\mathbf{x} \\ \frac{G_1}{M_2}T_1 - \frac{0.9333G_1}{M_2}T_2 - \frac{0.0667t_0}{cM_2} \end{bmatrix} + \begin{bmatrix} \mathbf{0} \\ \frac{0.9333T_2 - T_0}{M_2} \end{bmatrix} u_2 \end{aligned} \quad (7)$$

where

$$\dot{\mathbf{x}} = \begin{bmatrix} \dot{x}_1 \\ \dot{x}_2 \end{bmatrix}, \quad \mathbf{x} = \begin{bmatrix} x_1 \\ x_2 \end{bmatrix}, \quad \mathbf{A}_1 = \begin{bmatrix} 0 & 1 \end{bmatrix} \quad (8)$$

The sliding model motion equation is:

$$\dot{\bar{\mathbf{x}}} = (\mathbf{A}_{11} - \mathbf{A}_{12}\tilde{\mathbf{c}}^T)\bar{\mathbf{x}} \quad (9)$$

The linear transformation can be obtained as follows:

$$\begin{aligned} u_1 &= -\beta^{-1}(\mathbf{x})[\varepsilon sgn s_1 + k_1 s_1 + \\ &\quad \tilde{\mathbf{c}}^T(\mathbf{A}_{11} - \mathbf{A}_{12}\tilde{\mathbf{c}}^T)\bar{\mathbf{x}} + \alpha(\mathbf{x}) + \tilde{\mathbf{c}}^T \mathbf{A}_{12} s_1] \\ &= -\beta^{-1}(\mathbf{x})[\varepsilon sgn s_1 + k_1 s_1 + \tilde{\mathbf{c}}^T \mathbf{A}_1 x + \alpha(\mathbf{x})] \end{aligned} \quad (10)$$

Assuming s_2 denotes the switching function as follows:

$$\mathbf{s}_1 = \mathbf{s}_1(\mathbf{x}) = \begin{bmatrix} c_1 & 1 \end{bmatrix} \begin{bmatrix} x_1 \\ x_2 \end{bmatrix} = c_1 x_1 + x_2 \quad (11)$$

Then, the following expression can be acquired:

$$\mathbf{c}^T = [\tilde{\mathbf{c}}^T \quad 1], \quad \tilde{\mathbf{c}}^T = [c_1] \quad (12)$$

The linear transformation can be obtained:

$$\begin{bmatrix} \bar{\mathbf{x}} \\ \mathbf{s}_1 \end{bmatrix} = \begin{bmatrix} x_1 \\ \mathbf{s}_1 \end{bmatrix} = \mathbf{T} \begin{bmatrix} x_1 \\ x_2 \end{bmatrix}, \quad \mathbf{T} = \begin{bmatrix} \mathbf{I}_{n-1} & \mathbf{0} \\ & \mathbf{c}^T \end{bmatrix} = \begin{bmatrix} 1 & 0 \\ c_1 & 1 \end{bmatrix} \quad (13)$$

where

$$\mathbf{T}_1 = \begin{bmatrix} 1 \\ c_1 \end{bmatrix}, \quad \mathbf{T}_2 = \begin{bmatrix} \mathbf{0} \\ 1 \end{bmatrix} \quad (14)$$

According to the following equations:

$$\dot{\bar{\mathbf{x}}} = \dot{x}_1 = \mathbf{A}_{11}\bar{\mathbf{x}} + \mathbf{A}_{12}x_n = x_2 \quad (15)$$

$$\begin{aligned} \dot{\mathbf{s}}_1 &= \tilde{\mathbf{c}}^T \mathbf{A}_{11}\bar{\mathbf{x}}^T + \tilde{\mathbf{c}}^T \mathbf{A}_{12}x_n + \alpha(\mathbf{x}) + \beta(\mathbf{x})u_1 \\ &= c_1 x_2 + \alpha(\mathbf{x}) + \beta(\mathbf{x})u_1 \end{aligned} \quad (16)$$

the sliding model motion equation can be written as:

$$\dot{\bar{\mathbf{x}}} = \dot{x}_1 = (\mathbf{A}_{11} - \mathbf{A}_{12}\tilde{\mathbf{c}}^T)\bar{\mathbf{x}} + \mathbf{A}_{12}\mathbf{s}_1 = -c_1 x_2 + \mathbf{s}_1 \quad (17)$$

When $s_2 \equiv 0$, the equation of the sliding model can also be obtained:

$$\dot{x}_1 = -c_1 x_2 \quad (18)$$

Because (A_{11}, A_{12}) is controllable, the nonlinear system represented by the above phase coordinates is controlled, and the system will be asymptotically stable by assigning the pole $c_1 > 0$.

When the proportional reaching law is chosen:

$$\dot{s}_1 = -\varepsilon_1 \text{sgn}(s_1) - k_1 s_1 \quad (\varepsilon_1, k_1 > 0) \quad (19)$$

The solution of the SMVS controller is the mixed oil tank regulating valve's control input.

$$\begin{cases} u_1^+ = \left(\frac{T_0 - 0.9333T_2}{M_2}\right)^{-1} \left(c_1 x_2 + \frac{G_1}{M_2} T_1 - \frac{0.9333G_1}{M_2} T_2 \right. \\ \quad \left. - \frac{0.0667t_0}{cM_2} + k_1 c_1 x_1 + k_1 x_2 + \varepsilon_1 \right) & s_1 > 0 \\ u_1^0 = \left(\frac{T_0 - 0.9333T_2}{M_2}\right)^{-1} \left(c_1 x_2 + \frac{G_1}{M_2} T_1 - \frac{0.9333G_1}{M_2} T_2 \right. \\ \quad \left. - \frac{0.0667t_0}{cM_2} + k_1 c_1 x_1 + k_1 x_2 \right) & s_1 = 0 \\ u_1^- = \left(\frac{T_0 - 0.9333T_2}{M_2}\right)^{-1} \left(c_1 x_2 + \frac{G_1}{M_2} T_1 - \frac{0.9333G_1}{M_2} T_2 \right. \\ \quad \left. - \frac{0.0667t_0}{cM_2} + k_1 c_1 x_1 + k_1 x_2 - \varepsilon_2 \right) & s_1 < 0 \end{cases} \quad (20)$$

3.3 The solution of the heater steam regulating valve's control input

For the second-order linear system of equation (4), the following switching function can be taken:

$$s_2 = c_2 x_3 + x_4 \quad (21)$$

Once the system enters the sliding model, the following should be satisfied:

$$s_2 = c_2 x_3 + x_4 = \dot{x}_3 + c_2 x_3 = 0 \quad (22)$$

This is the system's sliding model equation, the solution of which is:

$$x_3(t) = x_3(0) e^{-c_2 t} \quad (23)$$

Obviously, only when $c_2 > 0$ are both the above solution and the variable structure system stable.

When the proportional reaching law is chosen:

$$\dot{s}_2 = -k_2 s_2 - \varepsilon_2 \text{sgn } s_2, \quad \varepsilon_2 > 0 \quad (24)$$

The solution of the SMVS controller is the heater steam regulating valve's control input.

$$\begin{cases} u_2^+ = \left(\frac{\lambda}{cM_1}\right)^{-1} \left(c_2 x_4 - \frac{G_1}{M_1} T_1 + \frac{G_1}{M_1} T_2 + k_2 s_2 + \varepsilon_2 \right) & s_2 > 0 \\ u_2^0 = \left(\frac{\lambda}{cM_1}\right)^{-1} \left(c_2 x_4 - \frac{G_1}{M_1} T_1 + \frac{G_1}{M_1} T_2 + k_2 s_2 \right) & s_2 = 0 \\ u_2^- = \left(\frac{\lambda}{cM_1}\right)^{-1} \left(c_2 x_4 - \frac{G_1}{M_1} T_1 + \frac{G_1}{M_1} T_2 + k_2 s_2 - \varepsilon_1 \right) & s_2 < 0 \end{cases} \quad (25)$$

4 Experimental studies

In order to verify whether the proposed multi-input nonlinear SMVS control algorithm is scientific or not, some experiments are now conducted in this paper [8]. The Windows-based Configuration 6.01 (KING VIKW 6.01) was adopted as the system's software, as it is used widely in the engineering field. The KING VIKW software is open and powerful, which can carry out the field data acquisition, process control, animation display, report output, real-time and historical data processing, alarm and security mechanism, trend curve and the function of the enterprise monitoring network. Common C language programming is used in this software environment.

The algorithm of PID and SMVS control were both adopted in the fuel oil viscosity and temperature control experiment. Firstly, data variables were defined in the data dictionary and then the C language programming was written. Part of the SMVS control algorithm program of the fuel oil viscosity and temperature control system, which is based on the linear reductive solution, is shown as follows:

```

    \ this site \ek1=\ this site \sp1-\ this site \pv2;
    \ this site \s11=\ this site \ek1+\ this site \s10;
    \ this site \s12=\ this site \c1*\ this site \s11+\ this
site \ek1;
    \ this site \s10=\ this site \s11;
    if(\ this site \s12>=0)
    {
        if(\ this site \s12>0)
        { \ this site \uk11=\ this site \c1*\ this site \ek1-\
this site \a1*\ this site \pv1-\ this site \b1*\ this site
\pv2+\ this site \k1; }
        else{ \ this site \uk11=\ this site \c1*\ this site
\ek1-\ this site \a1*\ this site \pv1 -\ this site \b1*\ this
site \pv2; }
    }
    else{ \ this site \uk11=\ this site \c1*\ this site \ek1-
\ this site \a1*\ this site \pv1-\ this site \b1*\ this site
\pv2-\ this site \k1; }

```

The experimental results of the fuel oil viscosity and temperature controlled by the PID and SMVS are shown in figures 2 and 3 respectively.

The temperature response record curves are recorded in figure 2 and figure 3 when the system is put into operation. The temperature of heavy oil when it flows from the heat exchanger to the main engine T_2 is set at 154°C and the temperature of heavy oil when it flows from the mixed oil tank to the heat exchanger T_1 95°C. For the temperature T_2 regulated by the PID method, it can be seen from the graph that the overshoot is larger at about 18%, and is unstable for a long time; moreover, the adjustment time of T_2 is longer, the stability is very poor, and there will be system errors. For the temperature T_2 controlled by the SMVS, it can be seen that the overshoot is not obvious at about 2%, which is crucial for temperature control. The regulation time of the temperature T_1 is short, the stability is good, and a fluctuation of the temperature value is prevented.

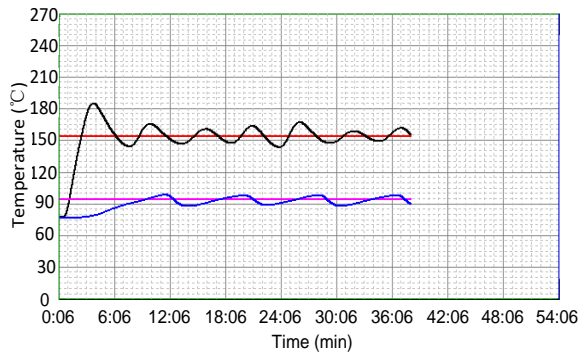

Fig. 2. The fuel oil temperature control experiment of PID.

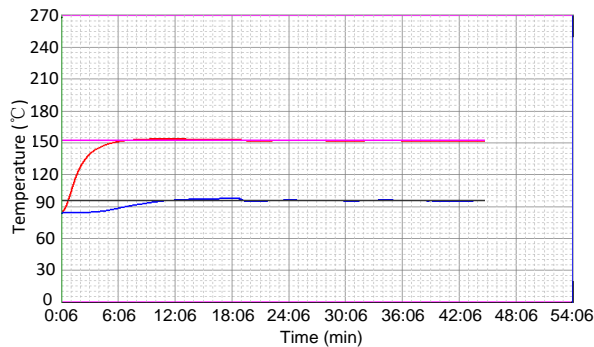

Fig. 3. The fuel oil temperature control experiment of SMVS.

4 Conclusions

The PID method is used widely in the control of a vessel's engine room system, because it is not necessary to establish a mathematical model and it has certain advantages, including a simple design [9]. However, it is difficult to set the optimal parameters, and once exposed to external disturbances or adjusted to factory parameters it will be difficult to recover the ideal control effect. The SMVS control needs to establish a precise mathematical model of the system, and the controller structure is complex, particularly the nonlinear control system [10]. However, the model and design of the control scheme, which is based on the characteristics of the original nonlinear object, has the following advantages: a wide range of applications, fast response, good dynamic and static quality and strong anti-jamming capability [11]. In the later study, two parameters of temperature and viscosity will be controlled.

This research project has been supported by the National Natural Science Foundation of China (51609191) and the Independent Innovation Project of the Wuhan University of Technology (2018-ND-A1-01). I'd like to express my gratitude.

References

1. Ishijima, Takashi and Shimada, Akiko, "An analysis of ring temperature, oil film temperature, oil film thickness and heat transfer on a piston ring of an IC engine in consideration of ring movement in a cycle," *2017 International Conference on the ASME Internal Combustion Engine Division*, pp. 665-676 (2017)
2. S. Tong, Y. Li, J. Ren and Y. Zhang, "PID control of air tank temperature system with parameters tuning through network," *2015 International Conference on Advanced Mechatronic Systems (ICAMEchS)*, Beijing, pp. 233-237(2015)
3. Wang Fenghua, Zhou xiang, Gao pei and Xi Xiaoguang, "Improved thermal circuit model of hot spot temperature in oil-immersed transformers based on heat distribution of winding," *High Voltage Engineering*, vol. 41, no. 3, pp. 895-901(2015)
4. U. M. Nath, C. Dey and R. K. Mudi, "Model identification of coupled-tank system — MIMO process," *2017 Second International Conference on Electrical, Computer and Communication Technologies (ICECCT)*, Coimbatore, pp. 1-6(2017)
5. Wu Sijie, Simulation Study of the Fuel Oil Viscosity Control System for Marine Diesel Engine [J], *Journal of Jimei University (Natural Science)*, vol. 5, 354-359(2013)
6. Sun huijuan and Li huazhou, "Coupling heat and mass transfer for a gas mixture-heavy oil system at high pressures and elevated temperatures," *International Journal of Heat and Mass Transfer*, vol. 74, 173-184(2014)
7. S. Kaseera, A. Kumar and L. B. Prasad, "Analysis of chattering free improved sliding mode control," *2017 International Conference on Innovations in Information, Embedded and Communication Systems (ICIIECS)*, Coimbatore, India, pp. 1-6(2017)
8. M. Navabi and H. Mirzaei, "θ-D based nonlinear tracking control of quadcopter," *2016 4th International Conference on Robotics and Mechatronics (ICROM)*, Tehran, pp. 331-336(2016)
9. V. K. Pandey, I. Kar and C. Mahanta, "Controller design for a 3-DOF helicopter using multiple models with second level adaptation," *2017 Indian Control Conference (ICC)*, Guwahati, pp. 99-104(2017)
10. Qin Hong, Li Weiwei and Zhang Lidong, "Temperature distribution during pre-heating process in a 0.12t/d oil shale retorting reactor," *Acta Petrolei Sinica(Petroleum Processing Section)*, vol. 32, 921-929(2016)
11. Akhlaghinia, Manoochehr and Torabi, " Experimental and simulation studies of heavy oil/water relative permeability curves: Effect of temperature," *Special Topics and Reviews in Porous Media*, vol. 4, 99-109(2013)