

# Determining single-phase earth fault location with applying short-term double earth fault

A.L. Kulikov<sup>1</sup>, V.Ju. Osokin<sup>1\*</sup>, and D.I. Bezdushniy<sup>1</sup>

<sup>1</sup>NSTU n.a. R.E. Alekseev, Nizhniy Novgorod, Russian Federation

**Abstract.** The single-phase earth faults location are the predominant type of damage in distribution networks of 6-35 kV. The problem of remotely determining the fault location during single-phase earth faults has not definitely accepted practical and accurate solution. The article proposes and substantiates the intellectual methods of determining the fault location with using artificial introduction of short-term double earth faults. In the future by recorded oscillograms of currents and voltages, an accurate calculation of the distance to the damage is assumed.

## 1 Introduction

Single-phase earth fault is the predominant type of damage in medium voltage distribution electrical networks [1-6]. The task of determining the fault location does not have no unambiguous solution [8-18] due to the specificity of electromagnetic transients under single-phase earth faults, caused primarily by the neutral point grounding [1, 7]

The long-term operation of the network with single-phase earth faults leads to increase accident rate and probability of the development of single-phase earth faults into multiphase short circuits, which could in turn cause significant economic damage.

Fast and accurate detection of fault location is one of the main condition for eliminating the emergency and restoring the normal operation of the electrical network.

Previously the proposed methods of synthetic introduction of two-phase earth faults [19-22] for determining the location of single-phase earth faults are prospective in used, but, unfortunately, have not yet found practical implementation in operating organizations, including due to low accuracy.

## 2 The fault location algorithm for single-phase earth faults

Short-term connection of ballast resistance to the reserve cell of the bus section of the 6-35 kV switchgear is

proposed for solving the problem of determining the location. A circuit breaker installed in the standby cubicles switchgear with a phase drive, whose the main contacts are closed between themselves and connected to the ground through ballast resistance.

After occurrence the single-phase earth fault, one of the undamaged phases of the circuit breaker is closed with ballast resistance, ensuring that a short-circuit current of a limited magnitude and time flows through the ballast resistance, thereby simulating a double earth fault [16, 17]. After registering current flowing through the ballast resistance, the circuit breaker is turned off and network operation mode is restored.

Figure 1 shows an equivalent circuit describing the current flow in the synthetic introduction of double earth fault, and the following designations are accepted:  $E_{ph1}$ ,  $E_{ph2}$ ,  $E_{ph3}$  – is the equivalent of system electromotive force;  $Z_S$  – equivalent resistance of system;  $z_L$  – line resistivity (Ohm/km);  $z_m$  – resistivity of mutual induction (Ohm/km);  $Z_{load}$  – equivalent load resistance;  $R_t$  – transient resistance in the place of single-phase earth faults;  $l$  – the actual distance to point of ground fault;  $R_b$  – ballast resistance;  $L$  – length of the line (km).

The use of the scheme shown in Figure 1, in phase coordinates [7], allows obtaining expressions to determine distances to the single-phase earth fault.

\* Corresponding author: [osokin-v92@mail.ru](mailto:osokin-v92@mail.ru)

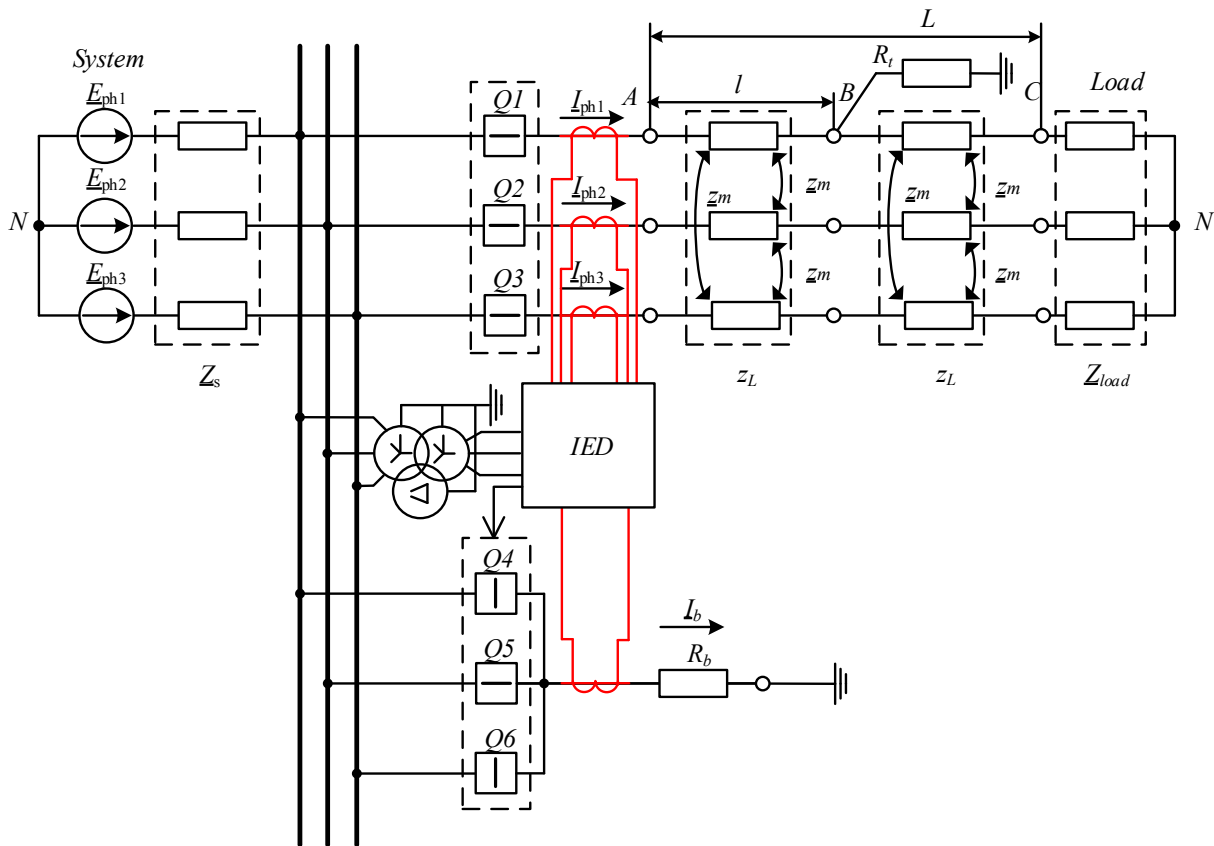

**Fig. 1.** The scheme for replacing the network in the single-phase earth fault mode with synthetic introduction of double earth fault

The equivalent circuit shown in figure 1 is converted to the form shown in figure 2 for the convenience of solving the scheme relatively to unknown parameters

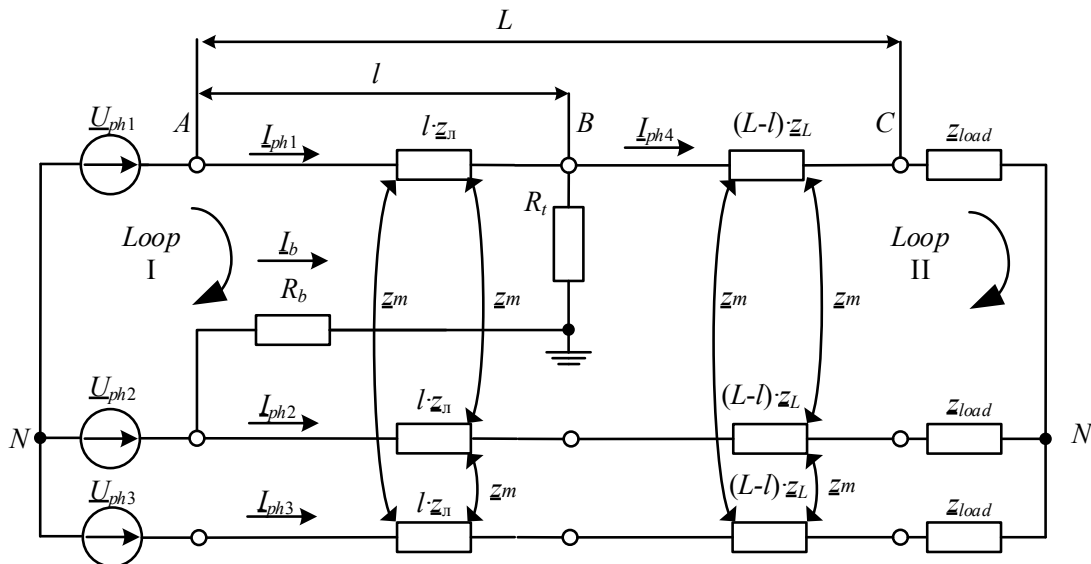

**Fig. 2.** The scheme for replacing the network in in double earth fault mode

Write Kirchhoff's voltage law for the first and second loops (figure 2), after specifying their current directions on the circuit.

From loop 1 of figure 2, and moving in a clockwise direction as indicated, gives the following expression:

$$\begin{aligned} I_{ph1} \cdot z_L \cdot l + (I_{ph2} + I_{ph3}) \cdot z_m \cdot l - \\ - I_b \cdot (R_b + R_t) = U_{ph1} - U_{ph2} \end{aligned} \quad (1)$$

The expression for the second loop is as follows

$$\begin{aligned} & \underline{I}_{ph4} \cdot (L-l) \cdot \underline{z}_L + \underline{I}_{ph4} \cdot \underline{z}_{load} + \\ & + (\underline{I}_{ph2} + \underline{I}_{ph3}) \cdot (L-l) \cdot \underline{z}_m - \\ & - \underline{I}_{ph2} \cdot (\underline{z}_{load} + \underline{z}_L) - \underline{I}_{\phi3} \cdot \underline{z}_m \cdot L - \\ & - \underline{I}_{\phi1} \cdot \underline{z}_m \cdot l - \underline{I}_{\phi4} \cdot \underline{z}_m \cdot (L-l) + \\ & + \underline{I}_{\phi} \cdot (R_{\phi} + R_n) = 0 \end{aligned} \quad (2)$$

Having expressed from the equation for the first circuit ( $R_b+R_t$ ) and substituting in equation (2), we obtain the equation for determining the distance to the point of damage.

$$\begin{aligned} l = & \frac{(\underline{I}_{ph1} + \underline{I}_b - \underline{I}_{ph2}) \cdot (\underline{z}_L \cdot L - \underline{z}_m \cdot L + \underline{z}_{load})}{\underline{I}_b \cdot (\underline{z}_L - \underline{z}_m)} - \\ & \frac{(\underline{U}_{ph1} + \underline{U}_{ph2})}{\underline{I}_b \cdot (\underline{z}_L - \underline{z}_m)} \end{aligned} \quad (3)$$

In general terms, the calculation expressions look like this:

$$\begin{aligned} l = & \frac{(\underline{I}_{dam.ph} + \underline{I}_b - \underline{I}_{ph.b}) \cdot (\underline{z}_L \cdot L - \underline{z}_m \cdot L + \underline{z}_{load})}{\underline{I}_b \cdot (\underline{z}_L - \underline{z}_m)} - \\ & \frac{(\underline{U}_{dam.ph} + \underline{U}_{ph.b})}{\underline{I}_b \cdot (\underline{z}_L - \underline{z}_m)} \end{aligned} \quad (4)$$

where,  $\underline{I}_{dam.ph}$  – the current of the damaged phase on which there was single-phase earth fault;  $\underline{I}_b$  – the current flowing through the ballast resistance;  $\underline{I}_{ph.b}$  – the current of the phase closed on the ballast resistance;  $\underline{U}_{dam.ph}$  – the voltage of the damaged phase on which the fault occurred;  $\underline{U}_{ph.b}$  – the voltage of the phase closed on the ballast resistance.

It should be noted that during the formation of the final ratio (4) substitution and compensation of the sum ( $R_b+R_t$ ) were realized, as a result of which the calculation of the distance to the single-phase earth faults location does not depend on the  $R_t$ . This circumstance is extremely important, since in networks with isolated and compensated neutral, almost all single-phase earth faults are followed by time-varying transient resistance. On the

other hand, the independence of  $l$  (expression (4)) from  $R_b$  emphasizes that the introduction of ballast resistance is necessary only to provide the required range of current and voltage fixation in case of short-term double earth fault.

In the equivalent circuit (figure 2) and obtained the expression (4) is not taken into account the influence of the active conductance and capacitance conductance of the line. In order to avoid possible distortion of calculations from capacitive conductivity of power lines, it is proposed to consider only the actual part of expression (4), and use of correction ratios, in further calculations, will reduce the influence of active conductivity on accuracy characteristics of obtained results.

In order to use expression (4), it is necessary to know the information about the parameters of the electric network that can be obtained by the operating organizations:

- from design or reference data ( $\underline{z}_L, \underline{z}_m, L$ ), taking into account the design of the power line;
- by analyzing data from operational measuring complexes, automated metering systems of electric energy, SCADA systems or by requesting dispatch services of consumers to obtain information about the load of the power line  $\underline{z}_{load}$ .

### 3 Results of the modelling

The accuracy of the obtained calculation algorithm (4) was estimated by simulating the damaged section of the electrical network in the Matlab software package in accordance with the scheme shown in Figure 3.

The considered scheme has the following parameters:

- voltage of 35 kV network;
- length of the lines  $Line_1=20$  km;  $Line_2=15$  km;  $Line_3=10$  km;
- specific resistance of the phase:  $\underline{z}_L=0.825+j0.6949$  Ohms/km;
- specific resistance of mutual induction:  $\underline{z}_m=0.0485+j0.3517$  Ohms/km;
- transient resistances  $R_t$  in the places of closures are determined by a random quantity distributed with uniform law in the range from 0 to 100 Ohms;
- load power consumption:  $\underline{S}_{load} = 45+j18.6$  MBA that corresponds to resistance  $\underline{z}_{load} = 16.242 + j6.713$  Ohms;
- ballast resistance  $R_b=100$  Ohms.

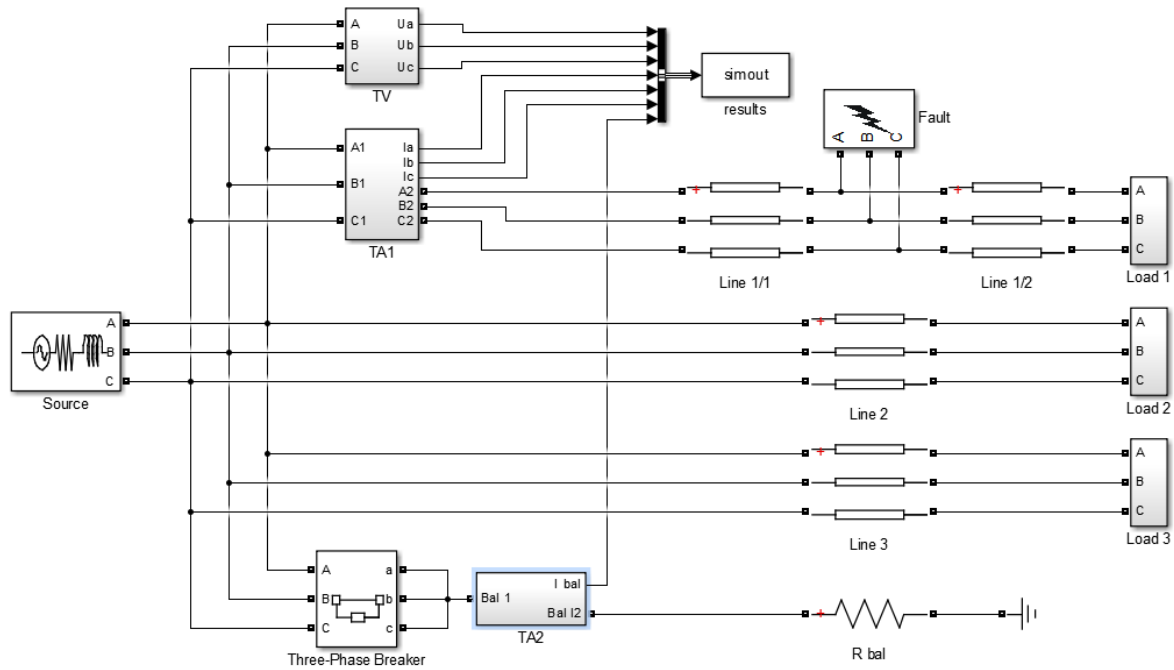

**Fig. 3.** Simulation modelling of the electrical network section in the mode of double earth fault

Network modeling was carried out in two stages. At the first stage, a model of power line with an inductive coupling between the phases was formed, and the transient resistance during single-phase earth faults was set randomly from a given range ( $R_f = 0 \dots 100 \text{ Ohm}$ ). As a result of simulation experiments, the dependence (Figure 4) of the calculated distances on the actual (i.e., set during the simulation) was constructed and the maximum error in estimating the distance to the single-phase earth faults location was determined.

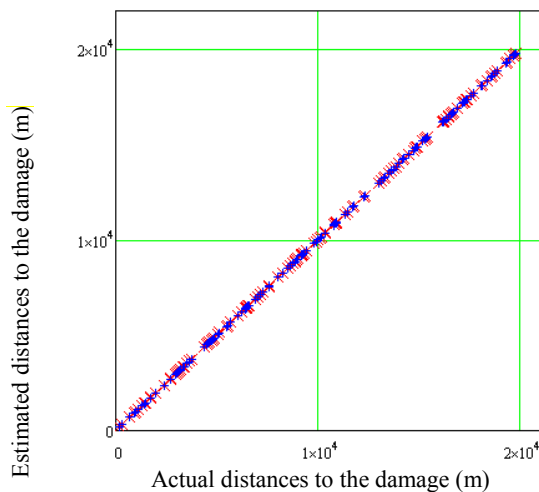
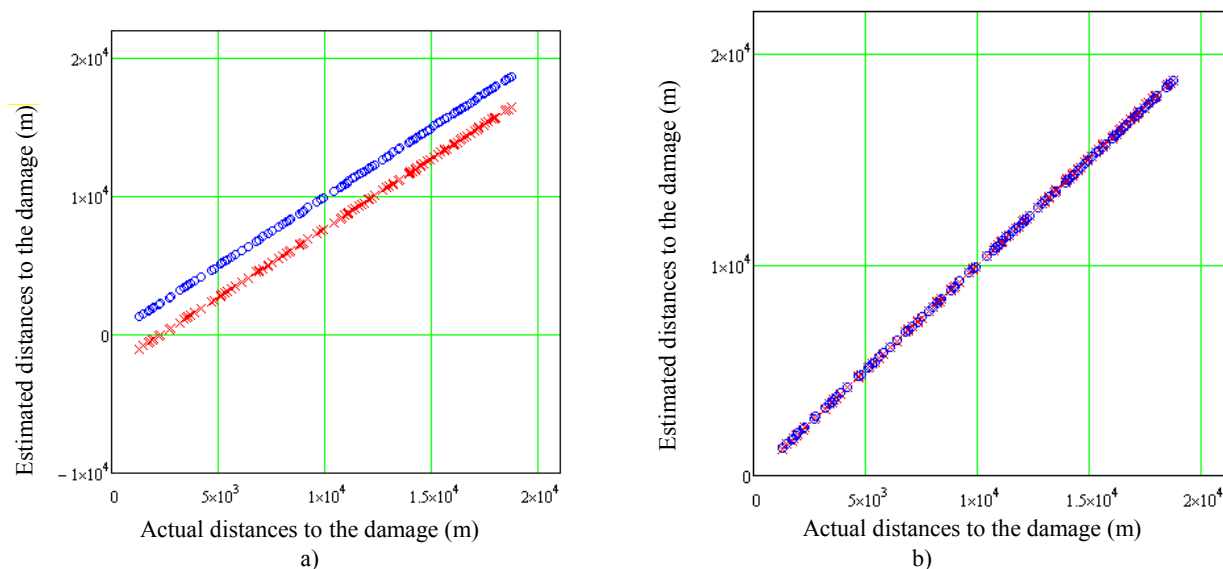

**Fig. 4.** Dependence of the estimated distances to the points of damage from the actual, in the absence of line conductivity

Analysis of the obtained results showed that due to the creation of a short-term artificial double earth fault and the use of a calculated algorithm appropriating to expression (4), it is possible to determine the distance to the single-phase earth faults location with an error not exceeding 1% of the line length. The maximum error of the calculated distance from the actual distance (Figure 4) was about 20 meters.

However, in practice, it is impossible to neglect existence of conductivity of the line, therefore, at the second stage of modeling the power line with the distributed parameters having capacitive conductivity  $3.04 \cdot 10^{-9} \text{ Sm/m}$  was imitated.

According to the results of simulation experiments, the maximum error of calculations by expression (4) was 12 %, and the maximum deviation of the calculated distances from the actual ones respectively was 1.5 km (figure 5A). The introduction of the correction ratio taking into account capacitive conductivity and the obtained dependence (Figure 5a), allows reducing the error of determination of distance to single-phase earth faults to the value of 1%, which according to the results of simulation is about 100 meters (Figure 5b)



**Fig. 5.** Dependence of the estimated distances to the points of damage from the actual, in the account of line conductivity

Thus, there is obtained fast and accurate algorithm for determining of single-phase earth faults on power transmission lines 6-35 kV, which will allow not only to reduce the time spent on elimination of damage and recovery of normal operation of the network, but also to significantly reduce the probability of damage transition to the short circuit, which is disconnected by the standard action of relay protection, and, as a result, to reduce the number of short-term power supply violations of consumers. The accuracy of the proposed algorithm in cable and cable-air networks can be reduced due to the presence of high-frequency discharge components of the transition current of the single-phase earth fault, as well as a significant influence of the total capacitive current of the network [1].

It is important to note that solving the problem of distance detection of the single-phase earth faults location in 6-35 kV distribution networks is one of the important tasks related to the implementation of the concept digital transformation accepted in 2018. The proposed algorithms can be widely used in digital complexes of relay protection and automation systems as part of digital distribution networks and digital substations.

## 4 Conclusions

1. The proposed algorithms allow to accurately determine the single-phase earth faults location in electric networks 6-35 kV with isolated or compensated neutral through the use of simulation, accumulation of statistical information and compensation of errors in real calculation on the simulation results.

2. An important advantage of the developed algorithms is the complete elimination of the influence of the transient resistance on the accuracy of determination of the single-phase earth fault location, and the introduction of a correction factor taking into account the uniform distribution of conductivity along

the length of the line allows to minimize the corresponding calculation error.

3. The proposed algorithms for determining the single-phase earth faults location due to short-term double earth faults can be implemented in modern relay protection devices and correspond to the concept of creating smart electrical networks (Smart Grid).

The reported study was funded by RFBR, project number 19-38-90144.

## References

- 1 V.A. Shuin, A.V. Gusenkov, *Zashchity ot zamykaniy na zemlyu v elektricheskikh setyakh 6-10 kV*, M.: NTF Energopro-gress, Bibliotekha elektrotehnika, P.104 (2001)
- 2 A. L. Kulikov, M. Sh. Misrikhanov, A. A. Petrukhin, *Opreделение mest povrezhdeniy LEP 6 – 35 kV metodami aktivnogo zondirovaniya*, – M.: Energoatomizdat, P.162 (2009)
- 3 E.A.Vorob'eva, D.I. Gandzhaev, G.A. Filatova, V.A. Shuin, *Informatsionnye parametry elektricheskikh velichin perekhod-nogo protsessa dlya opredeleniya mesta zamykaniya na zemlyu v raspredelitel'nykh kabel'nykh setyakh napryazheniem 6-10 kV*, *Vestnik IGEU*, **1.2.**, pp.34-42 (2017)
- 4 E.F. Khakimzyanov, R.G. Mustafin, A.I. Fedotov, *Opreделение rasstoyaniy do mest dvoynnykh zamykaniy na zemlyu na linii elektroperedachi raspredelitel'noy seti srednego napryazheniya*, *Izvestiya vuzov, Problemy energetiki*, **1.3-4**, pp.132-137 (2015)
- 5 A.N. Visyashchev, *Diagnostika sostoyaniya vozdukhnykh liniy elektroperedachi 10-110 kV v normal'nykh i avariynnykh rezhimakh*, *IrGTU, Uchebnoe posobie*, P. 270 (2012\_

- 6 Geoinformatsionnaya sistema OMP 6-35 kV. URL: [www.relematika.ru](http://www.relematika.ru) (data obrashcheniya: 17.07.2017) [www.relematika.ru/produkty/6-35\\_kv/sistema\\_omp\\_6-35\\_kv](http://www.relematika.ru/produkty/6-35_kv/sistema_omp_6-35_kv).
- 7 B.V. Papkov, *Toki korotkogo zamykaniya v elektricheskikh sistemakh*, Ucheb. Posobie NGTU, P.275 (2005)
- 8 Yu. S. Belyakov, *Aktual'nye voprosy opredeleniya mest povrezhdeniya vozdushnykh liniy elektroperedachi*, Bibliotekha energetika, prilozhenie k zhurnalu «Energetik», **11**, P.80 (2010)
- 9 A.L. Kulikov, M.D. Obalin, P.A. Kolobanov, *Kompleksnye algo-ritmy OMP LEP na baze statisticheskikh metodov*, *Energetik*, **1** (2012)
- 10 A. L. Kulikov, M. D. Obalin, P. A. Kolobanov, *Analiz i povyshenie tochnosti pri opredelenii mesta povrezhdeniya liniy elektroperedachi*, *Izvestiya vuzov. Elektromekhanika*, **5**, pp.57-62 (2013)
- 11 H. Diaz, M. López, *Fault location techniques for electrical distribution networks: a literature survey*, in *Proc. the Fifth IASTED International Conference*, pp. 311-318 (2005)
- 12 M. Lehtonen, *Novel techniques for fault location in distribution networks*, in *Proc. Power Quality and Supply Reliability Conference*, pp. 1-6 (2008)
- 13 A.L. Kulikov, V.V. Anan'ev, *Adaptivnoe volnovoe opredelenie mesta povrezhdeniya linii ehlektroperedach*, *Vestnik IGEU*, **1.4**, pp.21-25 (2014)
- 14 V.F. Lachugin., D.I. Panfilov, A.N. Smirnov, *Realizatsiya volnovogo metoda opredeleniya mesta povrezhdeniya na liniyakh elektroperedachi s ispol'zovaniem statisticheskikh metodov analiza dannykh*, *Izvestiya Rossiyskoy akademii nauk, Energetika*, **6**, pp.137-146 (2013)
- 15 A.L. Kulikov., M. D. Obalin, V.Ju. Osokin, T.R. Sharafeev, *Primenenie imitacionnogo modelirovaniya LEP 6–35 kV dlya povysheniya tochnosti opredeleniya rasstoyaniya do dvoynyh zamykanij na zemlyu*, *Vestnik IGEU*, **1**, pp.40-49 (2018)
- 16 A.L. Kulikov., V.Ju. Osokin, M. D. Obalin, *Povyshenie tochnosti algoritmov opredeleniya mesta povrezhdeniya LEP 6–35 kv pri dvoynyh zamykaniyah na zemlyu s pomoshch'yu vvedeniya iteracionnykh procedur*, *Elektroenergiya, peredacha i raspredelenie*, **1**, pp.54-59 (2019)
- 17 A.L. Kulikov., V.Ju. Osokin, M. D. Obalin, *Recovery time reduction of a damaged 6–35 kV transmission line after double earth fault applying the iteration fault location method*, *E3S Web of Conferences, Rudenko International Conference «Methodological problems in reliability study of large energy systems»* (2019)
- 18 A.L. Kulikov., V.Ju. Osokin, M. D. Obalin, *Improving Accuracy the Fault Location on Transmission Line 6–35 kV for Double Earth Fault*, *2018 ICIEAM*
- 19 A.L. Kulikov., V.Ju. Osokin, A. A. Loscutov, *Sposob opredeleniya mesta i rasstoyaniya do mesta odnofaznogo zamykaniya na zemlyu v elektricheskikh setyah 6–35 kV s izolirovannoy ili kompensirovannoy nejtral'yu*, Patent RF, no. 2685746, IPC G01R31/08, (2019)
- 20 A.L. Kulikov., V.Ju. Osokin, A. A. Loscutov, *Sposob opredeleniya mesta i rasstoyaniya do mesta odnofaznogo zamykaniya na zemlyu v elektricheskikh setyah 6–35 kV s izolirovannoy ili kompensirovannoy nejtral'yu*, Patent RF, no. 2685747, IPC G01R31/08, (2019)
- 21 V.A. Fastunov, *Sposob opredeleniya mesta i rasstoyaniya do mesta odnofaznogo zamykaniya na zemlyu v elektricheskikh setyah 6–35 kV s izolirovannoy ili kompensirovannoy nejtral'yu*, Patent RF, no. 2293342, IPC G01R31/08, (2007)
- 22 V.N. Pupynin., V.H. Nguen, *Ustrojstvo dlya opredeleniya rasstoyaniya do mesta odnofaznogo zamykaniya na zemlyu v setyah 6–35 kV elektricheskikh sistem s izolirovannoy ili kompensirovannoy nejtral'yu*, Patent RF, no. 2096795, IPC G01R31/08, (1997)