

Prediction of hydrogen sulfide emission from an energy dissipation chamber and assessment of its distribution in the ambient air

Anna Telyatnikova^{1,*}, Sviatoslav Fedorov¹, Iurii Stolbikhin¹ and Elena Korneeva^{1,2}

¹Saint Petersburg State University of Architecture and Civil Engineering, St. Petersburg, Russian Federation

²Peter the Great St. Petersburg Polytechnic University, St. Petersburg, Russian Federation

Abstract. Wastewater transport in sewer networks contributes to the formation and emission of fetid and toxic sewage gases into the environment, one of which is hydrogen sulfide. The emission of gases can have a significant impact on the environment and health of maintenance workers and city residents. The object of the research is the study of the process of hydrogen sulfide emission in the energy dissipation chamber (EDC). The method of two-stage mathematical modeling in the program of finite element analysis ANSYS CFX is applied for the research. Two models have been created, the first one simulates the internal space of the EDC structure itself, and the second one simulates the EDC manhole and the volume of the surrounding air next to it. Mathematical dependences of hydrogen sulfide concentration change at three sections inside the structure are obtained for incoming wastewater flow velocities $V = 1$ m/s, 1.5 m/s and 2 m/s. The critical flow velocities at which the maximum single threshold limit value will exceed 1 m/s and the threshold limit value of the working area will exceed 1.52 m/s are determined. The methodology for solving the problem of assessing the impact of the EDC object on the environment is formed. The results of the study can be applied in the design of structures for a preliminary assessment and prediction of the impact of a wastewater facility, as well as the selection of the most favorable hydraulic regime.

1 Introduction

Sewerage network operation is accompanied by the release of toxic and fetid gases (hydrogen sulfide, methane, ammonia) from manholes and ventilation pipelines. Danger of possible suffocation and poisoning [1 – 4] confirms the need to assess atmospheric air influence zone of sewerage facilities while designing them [5]. In future, boundaries of the sanitary protection zones should be established for the most «gas-emission» sewerage facilities. In cases when capital construction objects or other places of long-term stay of a human get inside these gases influence zones, it is necessary to provide installation of air purification equipment.

It is important to notice that these sewer gases are fetid, bad-smelling. It has been determined that the sensation of an unpleasant specific odor from the sewerage systems is observed at very low concentrations, which are not harmful to the health of living organisms. However, as practice shows, such aromatic pollution of the urban environment leads to discomfort, increased fatigue, reduced mental activity and general ability to work among the population. In the national standards of leading European countries special

attention is paid to the problem of aromatic pollution of the urban environment [6, 7].

These properties of sewage gases indicate the need to assess the sanitary state of the ambient air near sewerage system facilities. Up to date, in the Russian Federation, such an assessment methodology has been created only for wastewater treatment plant facilities. This work have been performed by JSC “Atmosphere research institute” and presented in special recommendations. There is no methodology for assessing the sanitary condition near sewerage networks (energy dissipation chamber (EDC), pumping station, drop wells, etc.), as well as a methodology for calculating their sanitary protection zone.

The study and analysis of international experience in the research field of gas emissions from sewerage systems (especially H_2S , as the most dangerous) confirms the absence of such methodologies. The main direction of studying H_2S in sewerage systems is its impact on the structural elements of networks (gas corrosion) [8 – 11]. Active research is also underway in the field of in-depth study of the physics of hydrogen sulfide mass transfer through the air-water phase boundary [12 – 15]. Attention is paid to the issue of odor intensity from sewerage system [16, 17] and its reduction [18, 19]. Work is also under way to study the factors affecting the gases emission within networks and their distribution.

* Corresponding author: sik3000@list.ru

Such factors include: climatic characteristics [20–22], the type of transportation networks (combined, separate) and hydraulic characteristics of the flow in them (slope, filling, length) [23, 24], the velocity of air masses movement in the headspace of structures and sewers [25], changes in pressure within the network [22], changes in properties and composition of wastewater [26–28].

Some of the previously mentioned studies [20, 21, 24] allow us to estimate the amount of H_2S formed inside single sewer sites and on sites consisting of a complex of networks and structures. However, up to date, there are no methods to determine the amount of gases that are released in specific sewerage facilities. In this issue, such facilities as EDC and drop wells provide more science interest. In this type of facilities due to a wastewater flow drop, an increased flow turbulization occurs, which contributes to the emission of gases. In addition, inside EDC the change in the type of water movement (from gravity to pressurized) occurs, which leads to a sharp increase in the contact area of the water-air phases. According to the authors, special attention should be paid to the determination of dependencies between the technological parameters of EDC and the amount of hydrogen sulfide released in them.

Therefore, the first task of this study was to determine the mathematical dependences of the amount of hydrogen sulfide released from the flow rate parameter of the wastewater entering the EDC. Subsequently, the numerical results of the mass flow of gas obtained at the first stage are used to study the process of hydrogen sulfide release from the manhole into the environment. The multiplicity of gas dilution in the ambient air near the EDC manhole is estimated.

2 Methods

In order to reach the objectives of the study it is required to create two mathematical models: the model of the internal space of the EDC (Fig. 1) and the model of the manhole with the area of the surrounding air (Fig. 2, 3).

It should be noticed that the majority of modern works on the study hydrodynamic and mass transfer processes use the method of mathematical modeling in finite element analysis programs [29–31]. No exception and modeling of the processes of emission, transfer, distribution and influence of H_2S [24, 32, 33]. Creation of models for our study was also carried out in the finite element analysis package ANSYS CFX.

2.1 Model of EDC interior space

The computational domain of the EDC model (Fig. 1) represents the airspace of the EDC, the inlet pressurized pipeline and the outlet gravity pipeline. The calculated area was performed in the DesignModeler application as a solid element, in which special cutout simulates the wall of the pressurized pipeline. Further, a computational mesh was generated for the created domain, and boundary and initial conditions have been specified. The inflow of a mixture of water and hydrogen sulfide into the domain is determined by the «Inlet» condition on the pressurized pipeline, which sets the rate of the incoming flow (V , m/s) and the ratio of the volume fractions of water and hydrogen sulfide (Volume fraction). In order to account the presence of air inside EDC, the condition “Opening” was used, in which the absence of gauge pressure ($P_m = 0$ Pa) was specified, as well as the ratio of the volume fractions of air, water and hydrogen sulfide. Since the “Opening” boundary is located near the manhole, at the initial time of calculation only the air medium is present at this boundary. The wastewater flow outlet is predefined by the “Outlet” condition, at which the absence of gauge pressure ($P_m = 0$ Pa) was specified. Thus, the gravity movement of the water flow through the outlet pipeline is provided, and water drags the air with it. In addition, each of the phases contains a certain admixture of hydrogen sulfide. As the initial condition, the condition of presence of the air only in a stationary state inside the domain was set at the initial instant of time ($\tau = 0$ s). Fig. 1 shows the calculated cross sections, at which the mass flow rate of hydrogen sulfide has been recorded, for further analysis of the simulation results.

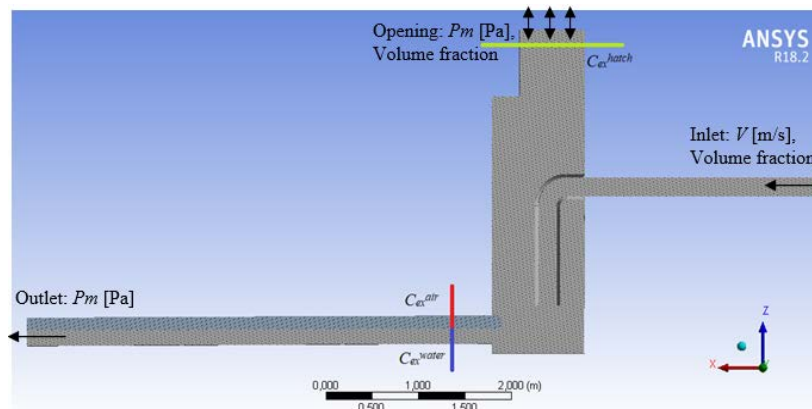

Fig. 1. The domain of the EDC model. Initial and boundary conditions. Cross-sections for results output.

During the first phase of the study, a series of experiments with varying rates of inflow wastewater to the “Inlet” boundary: $V = 1$ m/s, 1.5 m/s, 2 m/s was

carried out. The ratio of the volume fractions of water and hydrogen sulfide at the «Inlet» is assumed to be

constant and was 0.8 for water and 0.2 for hydrogen sulfide.

2.2 The model of the airspace near the EDC manhole

The computational domain of the second model is also performed as a solid element consisting of two parts connected to each other (Fig. 2). The first part simulates the internal airspace of the manhole cover elements through which gas can enter the environment (such elements are technological holes in the manhole cover and looseness of it) (Fig. 2, Pos. A). The second part is the ambient air near the EDC manhole (Fig. 2, Pos. B.). Overall dimensions of the second part of the model are $10 \times 10 \times 10$ m.

Special attention in this model was paid to the mesh generation. In order to optimize the calculation, the mesh was thinned only in the manhole cover zone and in the exit zone of the flow from the manhole. Changing the size of the mesh cells was carried out using the “Sizing” function. In the manhole cover zone, this function allowed the generation of a mesh with a cell size of 0.0015 m. The airspace above the manhole was divided into three areas using spheres with a radius of 1.5 m, 2.5 m, 4 m. The dimensions of the cells in these spheres were 0.06 m, 0.09 m, 0.12 m, respectively.

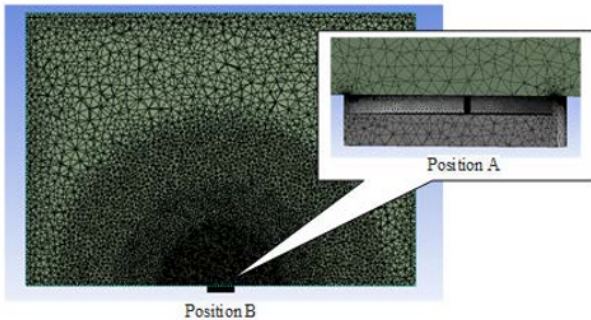

Fig. 2. The domain of the airspace model next to the manhole. The results of the mesh generation: position A – first part of the model (technological holes in the manhole cover), position B – second part of the model (ambient air environment near the manhole).

Subsequently, the initial and boundary conditions of the model were specified. In the computational domain, the presence of two substances was set: hydrogen sulfide and air. The temperature of hydrogen sulfide and air inside the manhole was 288 °K, the ambient air temperature for the first experiment was 298 °K, for the second experiment – 266 °K. Gas inflow into the computational domain was taken into account using the “InletGas” boundary condition (Fig. 3), at which the mass flow rate of gas was set while being obtained during the simulation at the first stage; gas volume fraction were also set at the “InletGas” boundary condition. The movement of air masses in the environment was simulated using the “InletWind” boundary condition applied to one of the faces (Fig. 3). The wind speed was 1 m/s. At the initial time, only air

with gauge pressure $P_m = 0$ Pa was present in the computational domain (“Opening” boundary condition).

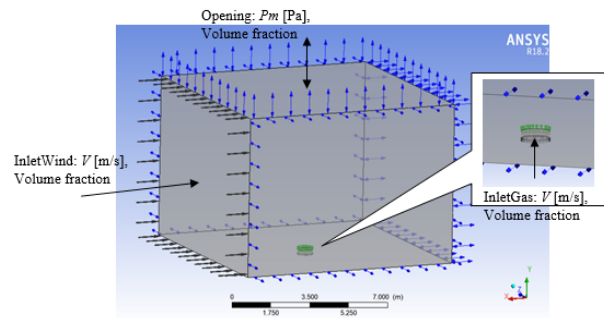

Fig. 3. Initial and boundary conditions of the airspace model next to the EDC manhole.

3 Results and Discussion

As a result of the simulation, the following hydrodynamic picture was obtained (Fig. 4). The figure shows the ratio of the volume fraction of water and gas-air medium, which occurred as a result of steady movement. Through a horizontal pressurized pipeline, the flow of a mixture of water and gas enters the EDC with full cross-section. The flow is orange, which corresponds to the ratio of volume fractions of water and hydrogen sulfide at the inlet section. After the flow has reached EDC, it enters a vertical riser and a transition of the flow to a circular spiral movement is observed. The vertical riser discharges wastewater into the EDC water energy dissipation well. At the exit of the riser, the flow drags the air into the chamber and gets aerated. Due to the formation of hydraulic jumps, active mixing of the air and water occurs. As a result of this, part of the hydrogen sulfide is released from the water into the headspace of the EDC. EDC is filled with a gas-water mixture to a level corresponding to the filling of an outlet gravity pipe at a given flow rate. After the energy dissipation well of the EDC, water leaves the domain of the model by outlet gravity sewer. The flow velocity and the cross-section filling of the outlet pipeline corresponds to the data provided in hydraulic tables by Lukinykh A. A.

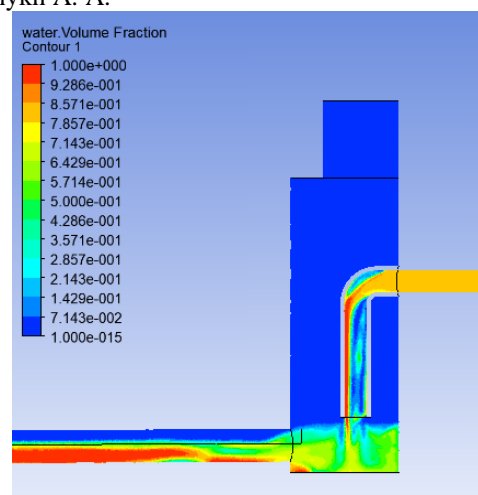

Fig. 4. EDC modelling results. Hydrodynamic picture.

Figure 5 shows the gauge pressure field in the domain of the model. Vacuum value in the inlet pipe is observed, the range is $P_{vac} = 123 - 402$ Pa. This result is explained by the insignificant value of the velocity head at the inlet pipeline and the creation of rarefaction in the vertical section when the water drops. Maximum gauge pressure $P_m = 529$ Pa is observed at the energy dissipation well in the point where the flow falls down. In the chamber near the energy dissipation well and the headspace of the outlet pipeline, a vacuum $P_{vac} = 215$ Pa is observed due to the dragging capacity of the water flow. In the upper part of the chamber near the manhole space there is a slight gauge pressure $P_m = 21$ Pa.

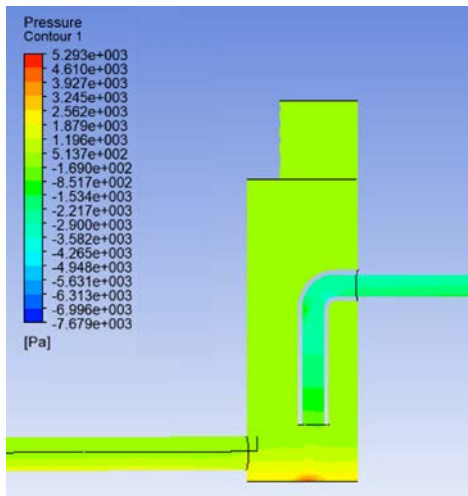

Fig. 5. Pressure field in the domain of the EDC model.

Figure 6 shows the streamlines of hydrogen sulfide streams released from water in the water energy dissipation well. From the streamlines, three pronounced gas flows can be considered. The first flow is due to the content of hydrogen sulfide, partially remaining in the aquatic environment after falling into the EDC and leaving the EDC through the outlet gravity pipeline with a water flow. Hydrogen sulfide that left EDC together with water continues to be released into the gas-air phase of the outlet pipeline. The second flow is caused by hydrogen sulfide, which is released into the underwater space of the chamber in the area of the hydraulic jump, circulates in it and, due to the dragging ability of water, is carried away by the air into the headspace of the outlet pipeline. The third flow is characterized by a constant circulation of hydrogen sulfide in the headspace of EDC. The third flow is the result of the formation of stagnant areas in the gas-air medium and is replenished with new

portions of gas from the second flow and from the free surface in the energy dissipation well. It is important to note that from the second and third flow hydrogen sulfide partially rises to the manhole, from where it is further released into the environment.

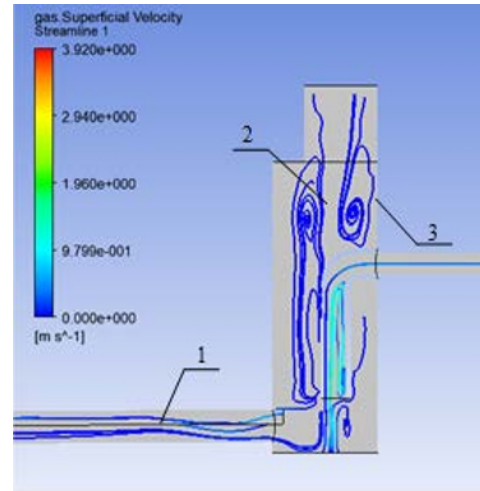

Fig. 6. Hydrogen sulfide streamlines in the EDC model.

The hydrodynamic picture obtained in EDC qualitatively corresponds to the expected results and the boundary and initial conditions. In addition, the filling of the energy dissipation well and the outlet gravity collector quantitatively corresponds to the existing data from the hydraulic tables. Trial series of calculations with different sizes of mesh cells was performed in addition. For the final calculation, the mesh cell size of $\delta = 0.31$ m was adopted; with less mesh cell size the calculation results did not actually change. On this basis, this model was found to be adequate and adopted to obtain the mass flow rate of hydrogen sulfide in the calculated cross sections (Fig. 1).

Fig. 7 represents a series of graphs obtained for the conditions of flow of wastewater into the domain with velocity $V = 2$ m/s. The calculation was performed for a non-stationary problem for a period of time $\tau = 1000$ s. Pulsation of hydrogen sulfide concentration was observed in all model calculations, so the field of calculated values of gas mass flow is observed in the graphs (Fig. 7). Approximation of the received field of points allowed to allocate regularity of change of concentration of hydrogen sulfide in all considered cross-sections using exponential law. The equations approximating the function for the three experiments are summarized in table 1.

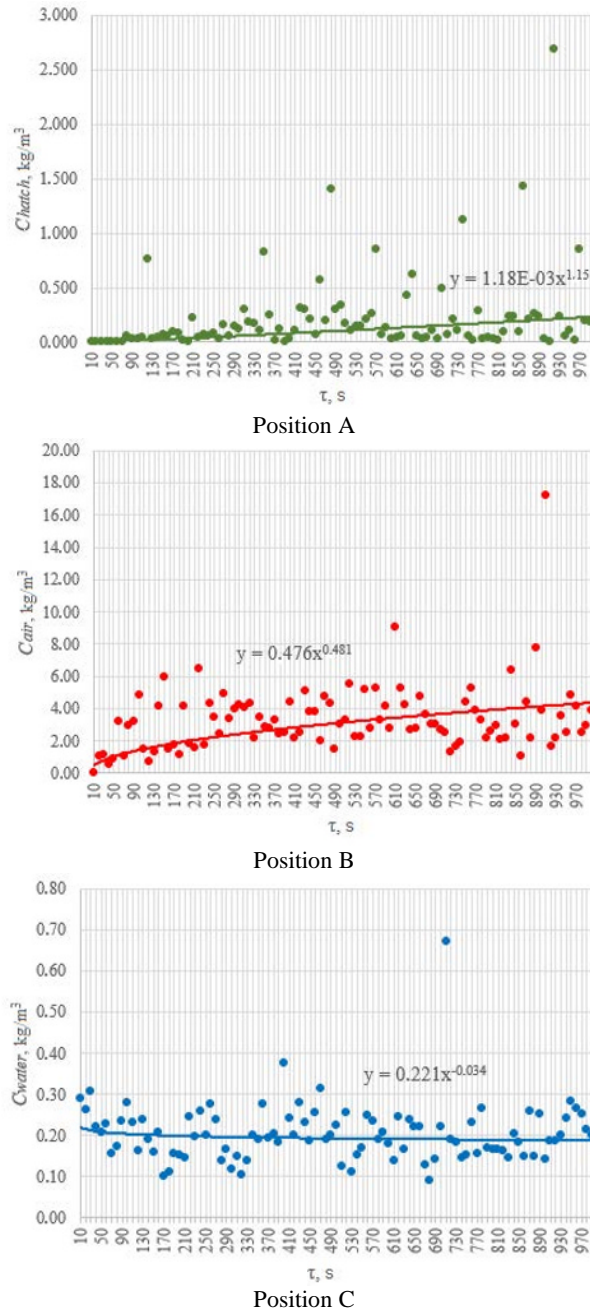

Fig. 7. Series of graphs obtained for the conditions of flow of wastewater into the domain with velocity $V = 2$ m/s. Functions of changing the concentration of hydrogen sulfide over time for cross-sections: position A – Cexhatch (close to the manhole), position B – Cexair (in the headspace of the outlet pipeline), position C – Cexwater (in the water phase of the outlet pipeline).

Table 1. Equations of approximating functions for a series of experiments to identify the dependence of the increase in the concentration of hydrogen sulfide (C_{ex} , kg/m³) on time (τ , s).

Equation	$V = 2$ m/s	$V = 1.5$ m/s	$V = 1$ m/s
$C_{ex}^{hatch} = f(\tau)$	$y = 1.18E-3x^{1.15}$	$y = 6.96E-11x^{1.87}$	$y = 1.35E-15x^{0.33}$
$C_{ex}^{air} = f(\tau)$	$y = 0.476x^{0.481}$	$y = 0.27x^{0.257}$	$y = 0.075x^{0.317}$
$C_{ex}^{water} = f(\tau)$	$y = 0.221x^{-0.034}$	$y = 0.199x^{-0.071}$	$y = 0.154x^{-0.032}$

In all experiments with three different inlet flow rates, an increase in the concentration of hydrogen sulfide is observed over time in the air space of the outlet pipeline and near the manhole. The concentration of H₂S flowing with the wastewater through the outlet pipeline

decreases over time. At the same time, it is important to note that the largest amount of hydrogen sulfide in the model leaves it together with the air flow at the outlet pipeline. This phenomenon is justified by the presence of the air dragging ability of the wastewater.

With an increase in the velocity of the wastewater, the turbulization of the flow and the rate of gas emission into the headspace of the sewerage network sufficiently increase. Comparing the results of various experiments, it can be noted that the concentration of hydrogen sulfide in the outlet pipeline for an inlet flow velocity of 2 m/s increased by 4.6 times compared with the experiment, where the wastewater velocity was 1.5 m/s; in 12.7 times compared with the experiment, where the wastewater velocity was 1.0 m/s. For the cross-section near the manhole, the concentrations observed at the inlet flow velocity $V = 1 \text{ m/s}$ were very small. Therefore, the selection of the speed of movement of the wastewater may be a criterion for the safe operation of the facility.

By interpolating the average concentration values for the experiments, it was determined that the excess of the

maximum single threshold limit value ($TLV_{m.s.} = 0.008 \text{ mg/m}^3$) occurs at a wastewater flow velocity $V \geq 1.1 \text{ m/s}$. Exceeding the threshold limit value for the working area ($TLV_{w.a.} = 10 \text{ mg/m}^3$) occurs at an inlet flow velocity $V \geq 1.52 \text{ m/s}$. Based on the data of the EDC model with an inlet flow velocity of 2 m/s and the obtained functional dependencies, a model of the air space near the sewer manhole was developed. The aerodynamic picture that was obtained as a result of model calculations is shown in Fig. 8. In both experiments conducted at different ambient temperatures, the formation of an H_2S emission plume was observed. At a negative ambient temperature (Fig. 8, pos. B), the plume also decreased due to the resulting stratification of air masses. The formation of the “loop” of the flow happened at a height of 12 m from the earth surface.

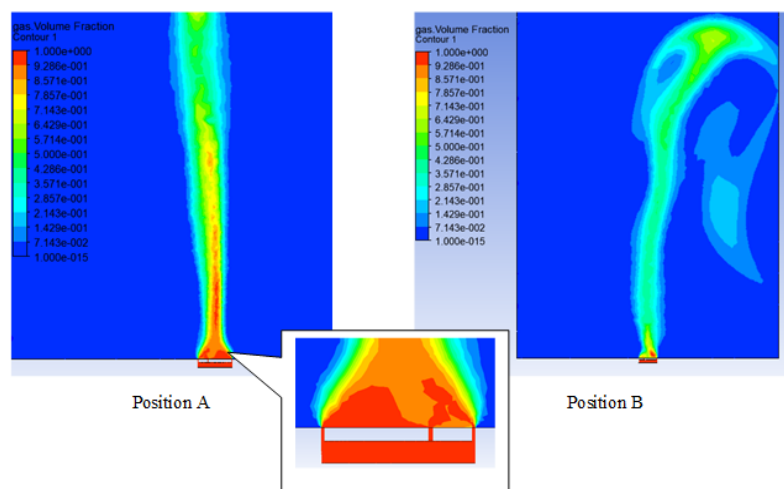

Fig. 8. Modelling results of the airspace next to the EDC manhole. Hydrodynamic picture: position A – at ambient temperature $t = 298 \text{ }^\circ\text{K}$, position B – at ambient temperature $t = 266 \text{ }^\circ\text{K}$.

The development of this model makes possible to evaluate the dilution ratio of H_2S at the control site. In the future, this will make it possible to assess the environmental impact of the sewerage system facility. In addition, the value of the dilution factor of the gas emission will allow us to assess the degree of reduction of the aromatic potential from the facilities at the design stage.

4 Conclusions

This study allowed:

- to formulate a fundamental methodology for solving the problem of assessing the impact of EDC on the environment. The methodology foresees two-stage modeling. At the first stage, the operation of EDC with the assessment of the mass flow rate of hydrogen sulfide released from the wastewater stream is considered. At the second stage, the process of hydrogen sulfide distribution in the airspace of the environment is simulated, and the concentration at the boundaries of the computational domain is estimated. A qualitative and quantitative assessment of the simulation results is carried out.

- Using simulation of the operation of EDC, it is possible to obtain the mathematical dependences of the emission of hydrogen sulfide from the wastewater flow into the headspace of the chamber and the sewerage network. The obtained functional dependences allow predicting the amount of gas for long periods of the facility operation.

- to obtain the values of the wastewater flow rate, at which the intensity of gas emission increases and the environmental sanitary requirements are violated. The concentration of hydrogen sulfide near the manhole exceeds $TLV_{m.s.} = 0.008 \text{ mg/m}^3$ at $V \geq 1.1 \text{ m/s}$, and $TLV_{w.a.} = 10 \text{ mg/m}^3$ at $V \geq 1.52 \text{ m/s}$. Values of permissible wastewater velocities can be used in the design standards.

These results of the scientific research are recommended to be used when designing new structures, as well as for setting up the work of existing facilities in order to reduce their impact on atmospheric air.

References

1. D. Burlet-Vienney, Y. Chinniah, A. Bahlou, B. Roberge, Occupational safety during interventions in confined spaces, *Safety Science* **79**, 19-28 (2015)
2. P. Ng, T.B. Hendry-Hofer, A. Witeof, M. Brenner, S. Mahon, G. Boss, P. Haouzi, V. Bebartha, Hydrogen Sulfide Toxicity: Mechanism of Action, Clinical Presentation, and Countermeasure Development, *Journal of Medical Toxicology* **15**, 1-8 (2019)
3. S. Chauhan, Hydrogen Sulfide (H₂S) - Poison Gas to Signaling Molecule in Regulation of Human Biology, *Journal of pharmacology & clinical research* **5**, 1-12 (2018)
4. E. Voskresenskaya, L. Vorona-Slivinskaya, V. Snetkov, A. Ponomarenko, Ecological and economic mechanism for the formation of environmental measures in the gas extraction constructions, *E3S Web of Conferences* **91** (2019)
5. M. Bolsunovskaya, A. Leksashov, A. Loginova, S. Shirokova, Hardware-software geo-information system for positioning objects, *E3S Web of Conferences* **91** (2019)
6. DIN EN 752:2017. Drain and sewer systems outside buildings - Sewer system management 100 (2017)
7. BS EN 752:2017 Drain and sewer systems outside buildings - sewer system management 130 (2017)
8. L. Xuan, L. O'Moore, S. Yarong, P. Bond, Y. Zhiguo, W. Simeon, L. Hanzic, J. Guangmin, The rapid chemically induced corrosion of concrete sewers at high H₂S concentration, *Water Research* **162**, 95-104 (2019)
9. J. Vollertsen, A. Nielsen, H. Jensen, T. Wium-Andersen, T. Hvitved-Jacobsen, Corrosion of concrete sewers - The kinetics of hydrogen sulfide oxidation, *The Science of the total environment* **394**, 162-170 (2008)
10. E. Kuliczowska, A. Parka, The structural integrity of corroded concrete sewers, *Engineering Failure Analysis* **104**, 409-421 (2019)
11. X. Sun, G. Jiang, B. Philip, K. Jurg, Impact of fluctuations in gaseous H₂S concentrations on sulfide uptake by sewer concrete: The effect of high H₂S loads, *Water Research* **81**, 84-91 (2015)
12. C. Lucie, F. Springer, G. Lipeme Kouyi, P. Buffière, A review of sulfide emissions in sewer networks: Overall approach and systemic modelling, *Water Science and Technology* **73**, 1231-1242 (2015)
13. C. Lucie, F. Springer, G. Lipeme Kouyi, P. Buffière, Influence of relative air/water flow velocity on oxygen mass transfer in gravity sewers, *Water Science and Technology* **75**, 1529-1538 (2017)
14. C. Lucie, F. Springer, G. Lipeme Kouyi, P. Buffière, Sulfide emissions in sewer networks: Focus on liquid to gas mass transfer coefficient, *Water Science & Technology* **75**, 1899-1908 (2017)
15. K. Teuber, T. Broecker, Using computational fluid dynamics to describe H₂S mass transfer across the water-air interface in sewers, *Water Science & Technology* **79**, 1934-1946 (2019)
16. B. Wang, E. Sivret, Parcsi, G., X. Wang, N. Le, S. Kenny, H. Bustamante, R. Stuetz, Is H₂S a suitable process indicator for odour abatement performance of sewer odours? *Water science and technology: a journal of the International Association on Water Pollution Research* **69**, 92-98 (2014)
17. J. Vollertsen, N. Revilla, T. Hvitved-Jacobsen, H. Asbjørn, Modeling Odors and Hydrogen Sulfide in the Sewers of San Francisco, *Proceedings of the Water Environment Federation* 1-11 (2014)
18. E. Sivret, R. Stuetz, Sewer odour abatement monitoring - An Australian survey. *Water science and technology: a journal of the International Association on Water Pollution Research* **66**, 1716-1721 (2012)
19. E. Sivret, B. Wang, G. Parcsi, S. Kenny, H. Bustamante, R. Stuetz, Beyond H₂S: Applying Gas Chromatography to Characterise Sewer Odour Emissions, *Proceedings of the Water Environment Federation* 60-73 (2012)
20. E. Eijo-Rio, A. Petit-Boix, G. Villalba, M. Suárez-Ojeda, D. Marín, M. Amores, X. Aldea, J. Rieradevall, X. Gabarrell Durany, Municipal sewer networks as sources of nitrous oxide, methane and hydrogen sulphide emissions: A review and case studies, *Journal of Environmental Chemical Engineering* **3**, 2084-2094 (2015)
21. R. Ventura Matos, F. Ferreira, J. Saldanha Matos, Influence of Intermittence and Pressure Differentials in Hydrogen Sulfide Concentration in a Gravity Sewer, *Water* **11**, 1780 (2019)
22. Z. Zuo, J. Chang, Z. Lu, M. Wang, Y. Lin, M. Zheng, D. Zhu, T. Yu, Y.C. Liu, Hydrogen sulfide generation and emission in urban sanitary sewer in China: What factor plays the critical role? *Environmental Science: Water Research & Technology* **5**, 839-848 (2019)
23. S. V. Fedorov, V. M. Vasil'ev, M. N. Klement'ev, Study of gas evolution in a sewer section. *Water supply and sanitary technique* **5**, 54-59 (2019)
24. G. Mannina, P. Calabrò, G. Viviani, *Mathematical Modelling of In-Sewer Processes as a Tool for Sewer System Design*. In: Mannina G. (eds) *New Trends in Urban Drainage Modelling*. UDM 2018. Green Energy and Technology. Springer, Cham (2019)
25. Y. Qian, D. Zhu, S. Edwini-Bonsu, Air Flow Modeling in a Prototype Sanitary Sewer System, *Journal of Environmental Engineering (United States)* **144** (2018)
26. C. Yongsiri, T. Hvitved-Jacobsen, J. Vollertsen, N. Tanaka, Introducing the emission process of hydrogen sulfide to a sewer process model, *Water Science and Technology* **47**, 85-92 (2003)

27. A. Nielsen, C. Yongsiri, T. Hvitved-Jacobsen, J. Vollertsen, Simulation of sulfidebuildup in wastewater and atmosphere of sewer networks, *Water Science and Technology* **52**, 201-208 (2005)
28. M. C. Almeida, D. Butler, J. W. Davies, Modelling in-sewer changes in wastewater quality under aerobic conditions, *Water Science and Technology* **39**, 63-71 (1999)
29. Y. Galerkin, K. Soldatova, Analysis of gas motion in the clearance between the cover disk and the casing of centrifugal compressor stage, *Chemical and Petroleum Engineering* **43**, 270-274 (2007)
30. E. Smirnov, Recent Progress in Numerical Simulation of Highly Three-Dimensional Turbulent Flows and Endwall Heat Transfer in Turbine Blade Cascades, *Heat Transfer Research* **42**, 1-18 (2009)
31. A. Pospelov, A. Zharkovskii, Effect of the Parameters of a Computational Model on the Prediction of Hydraulic Turbine Characteristics, *Power Technology and Engineering* **49**, 159-164 (2015)
32. K. Teuber, T. Broecker, S. Jaydev, M. Gebregziabher, M. Sielaff, D. Despot, D. Stephan, M. Barjenbruch, R. Hinkelmann, *Multiphase CFD-Simulation of Transport Phenomena in Sewer Systems*, New Trends in Urban Drainage Modelling. UDM 2018. Green Energy and Technology Springer, Cham (2019)
33. M. Lavasani, R. Rahimi, M. Zivdar, M. Kalbassi, CFD Modeling to Predict Mass Transfer in Multicomponent Mixtures, *Chemical Product and Process Modeling* **10**, 291- 302 (2019)