

Identification power line sections with increased electricity losses using sensors with Wi-Fi technology for data transmission

Igor Nikolaevich Fomin^{1,*}, Roman Pavlovich Belikov², Tatyana Anatolyevna Kudinova³, and Alexei Nikolaevich Tsvetkov⁴

¹Orel State Agrarian University named after N.V. Parakhin, Orel, Russia

²Orel State Agrarian University named after N.V. Parakhin, Orel, Russia

³Orel State Agrarian University named after N.V. Parakhin, Orel, Russia

⁴Kazan State Power Engineering University, ul. Krasnoselskaya 51, Kazan, Russia

Abstract. Modern highly mechanized and electrified agriculture places high demands on power supply reliability and uninterrupted work. To increase the reliability of power supply to agricultural consumers, in some cases, taking into account the configuration of electric distribution networks and the availability of responsible consumers, a conditionally closed ring network is created. Interruptions in power supply lead to downtime of agricultural production, a decrease in the volume of output, damage to the main technological equipment [1, 2]. In this regard, there is a need to make informed decisions on the choice of ways to increase the reliability of uninterrupted power supply due to the reservation of various elements of the power supply system, improving the organization of maintenance, and the operational diagnostics of faulty elements.

1 Introduction

To increase the reliability of power supply, power lines are partitioned. In addition, electricity is reserved, i.e. radial sectioned lines can be connected by a point of automatic transfer switch (ATS) with the formation of a conditionally closed ring network [1]. However, despite the technical support of the regulatory levels of power supply reliability, equipment failure of the power supply system may occur, such as a spurious tripping of the sectionalizing circuit-breaker in the power line. The shutdown may be caused by any malfunction or non-selective protection action. In order to timely receive information about the spurious tripping of the sectionalizing circuit-breaker in such a network, a new method of remote control has been developed.

2 Theoretical research

Analysis of the statistical data on the change in the inrush current in the ring network line at characteristic time intervals [2] gave full visibility of the processes and was the source of the necessary material for the development of remote monitoring methods [3,4,5]. Investigations of the authors [6] revealed the signs that allow remote monitoring of the false shutdown of the sectioning switch. Based on this, a new method has been developed to control the spurious tripping of the sectionalizing circuit- breaker in the ring network line.

According to this method, a change in current is monitored at the beginning of the main power supply line, and if a drop in the operating current to a value determined by the load of the line connected after the sectionalizing circuit-breaker is detected, and there is no short-circuit current inrush at this time, then the countdown equal to the delay time of the switching-on of the point switch of the ATS is started. At the end of the countdown of this time, the appearance of a current surge at the beginning of the backup power supply line is controlled, and if a current surge occurs, by a value determined by the disconnected load of the main power supply line and no short circuit current occurs, then the fact of a spurious tripping of the sectionalizing circuit-breaker is established [7].

To implement such control, Figure 1 shows a circuit of a conditionally closed ring network and a block diagram. The scheme works as follows. In normal mode, the monitored sectionalizing circuit-breaker Q2 is turned on and consumers S1, S2 are powered from the buses of the power transformer of the main power source T1 (see Fig. 1).

At the output of CT 1 and CT 12 there is a certain value of the output signal (Fig. 2, diagram 1 and diagram 12), due to operating currents, but insufficient for tripping of SCCS 2, OSC 3 and SINGLE-VIBRATOR 13. Presence of the output signal from the element NOT 4, coming to the element MEMORY 11, and from the element NOT 5, coming to the first input of the circuit element AND 7, does not lead to their operation. The circuit does not start.

* Corresponding author: igor.fom-in@yandex.ru

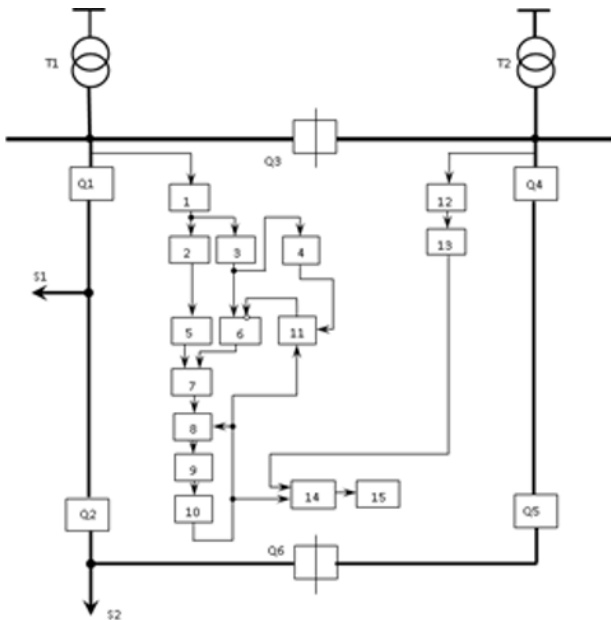

Fig. 1. Diagram of a conditionally closed ring network and a structural diagram of remote control.

In the diagram: T1 - power transformer of the main power source; T2 - power transformer of the reserve power source; Q1 - head circuit-breaker of the main power supply line; Q2 - sectionalizing circuit-breaker of the main power supply line; Q3 - substation sectionalizing circuit-breaker; Q4 - head circuit-breaker of the reserve power supply; Q5 - sectionalizing circuit-breaker of the reserve power supply line; Q6 – circuit-breaker of the point ATS; S1, S2 - line load of the main power supply; 1- current transformer (CT), 2- short circuit current sensor (SCCS), 3 - operating current sensor (OCS); 4 - element NOT; 5 - element NOT; 6 - the element INHIBIT; 7 - element AND; 8 - element MEMORY; 9 - element DELAY; 10 - element REPEATER; 11 - element MEMORY; 12 - CT; 13 - SINGLE-VIBRATOR; 14-element AND; 15 - recording device (RD).

If the sectionalizing circuit-breaker Q2 is switched off false, at the beginning of the line a drop in the operating current will be observed (Fig. 2, time point t_1). At the output of CT 1 (Fig. 2 diagram 1), the output signal will decrease by a value determined by the line load connected after the sectionalizing circuit-breaker Q2, which is fed to the input SCCS 2 and OSC 3. The value of the output signal CT 1 will not be sufficient for tripping SCCS 2, therefore, a signal does not appear at its output (Fig. 2, diagram 2), which would be input to the element NOT 5. The signal will not disappear from the output of the element NOT 5 (Fig. 2, diagram 5).

At the output of the OSC 4, which is triggered when the operating current drops to a value determined by the line load switched on after the sectionalizing circuit-breaker, a signal will appear (Fig. 2 diagram 4), which will be input to the element INHIBIT 6 and element NOT 4. The signal will disappear from the output of element NOT 4 (Fig. 2 diagram 4). At the output of element INHIBIT 6, a signal will appear (Fig. 2, diagram 6) and will go to the second input of element AND 7.

The simultaneous presence of two input signals at the input of element AND 7 will lead to the appearance of its output signal (Fig. 2, diagram 7), which will go to input of element MEMORY 8. This signal will be remembered by element MEMORY 8 (Fig. 2 diagram 8) and will go to the input of element DELAY 9.

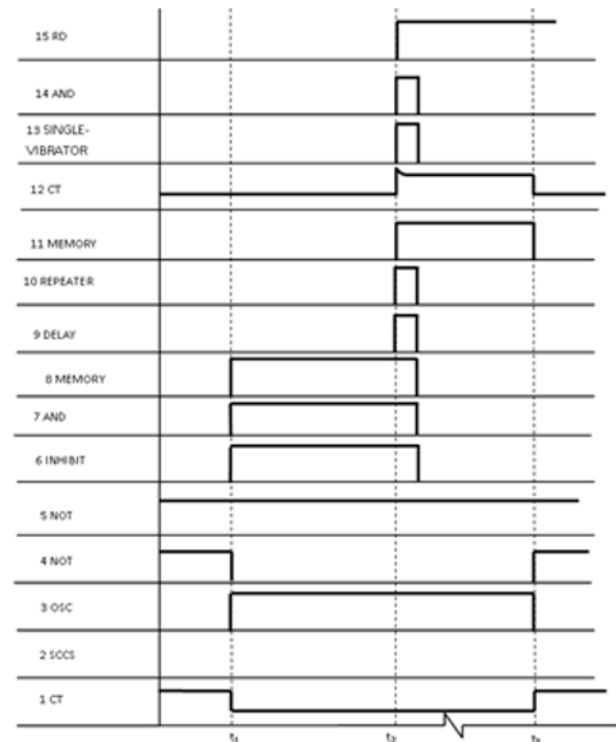

Fig. 2. The diagrams of the output signals of the structural diagram: t_1 –time point of the spurious tripping of the sectionalizing circuit-breaker S2; t_2 –time point of turning on the point switch of the ATS; t_3 – time point of normal operation mode restoration.

From the output of element 14, the signal appears after a time equal to the delay time of the switching-on of the point switch of the ATS (Fig. 2 time interval is t_1 - t_2). After counting the delay time of the switching-on of the point switch of the ATS, the signal from the output of element DELAY 9 (Fig. 2 diagram 9) will be input to element REPEATER 10. Element 10 will give a single impulse (Fig. 2 diagram 10), which will go to the input of the element MEMORY 11, to the input of the element AND 14 and "reset" the element MEMORY 8. This signal will be remembered by the element MEMORY 11, from the output of which the signal (Fig. 2, diagram 11) will go to the inhibitory input of the element 6. At the output of the element INHIBIT 6, the signal will disappear (Fig. 2, diagram 6) entering the second input of the element AND 7. In this case at the output of element AND 7, the signal will also disappear (Fig. 2, diagram 7). If the circuit-breaker of the ATS point is turned on at the same time, then the output of the CT 12 will have a signal (Fig. 2 diagram 12), increased by a value determined by the load of consumers S2. The magnitude of this signal is sufficient for operation of the SINGLE-VIBRATOR 13. The output signal from the SINGLE-VIBRATOR will go to the second input of element AND 14. The presence of two input signals at

AND 14 will cause the signal to appear at its output (Fig. 2, diagram 14). The output signal from AND 14, having entered the RD 15, will provide information in it about the spurious tripping of the sectionalizing circuit-breaker.

When normal operation mode is restored (Fig. 2, time point t_3), the controlled sectionalizing circuit-breaker Q2 will turn on and consumers S2 will be powered by the buses of the power transformer of the main power source T1 (see Fig. 1). At the output of CT 1 and CT 12 there will be a certain value of the output signal (Fig. 2, diagram 1 and diagram 12), due to operating currents, but insufficient for tripping of SCCS 2 and SINGLE-VIBRATOR 13. At the output of OSC 3, which is triggered when the operating current drops to a value determined by the line load connected after the sectionalizing circuit-breaker, the signal (Fig. 2, diagram 3) which was input to element INHIBIT 6 and element NOT 4 will disappear. A signal which will “reset” the element MEMORY 11 will appear at the output NOT 4 (Fig. 2 diagram 4). The circuit will return to the initial state of control [8].

3 Technical implementation

The proposed remote control method is implemented in a device for monitoring the spurious tripping of a sectionalizing circuit-breaker in a ring network line based on an analog-to-digital converter, with subsequent processing of the data by software on a computer.

Structurally, it consists of two blocks [9, 10]. One of the blocks is the current sensor connection block. The second block is necessary for converting and analyzing the input signal, as well as for generating and transmitting digital data to a computer for further analysis (information processing block) [11].

The algorithm of the above-described structural diagram of the remote method, implemented in the device, while simulating the situations of spurious tripping of the sectionalizing circuit-breaker during laboratory studies, has proved its operability. During the experiments, the remote monitoring software [12-14] correctly recognized the simulated situation of a spurious tripping of the circuit-breaker during each test.

Thus, the developed device makes it possible to receive timely information about the spurious tripping of the sectionalizing circuit-breaker in the ring network line.

4 Conclusions

1. The proposed method of remote control makes it possible to receive timely information about the spurious tripping of the sectionalizing circuit-breaker in the ring network line.
2. Laboratory tests fully confirmed the performance of the developed technical means.
3. The implementation of the proposed method will increase the reliability of power supply to consumers by taking the necessary decisions based on the information received by operational personnel.

References

- [1] L.D. Surov, I.N. Fomin, Control Failure of Automatic Reclosing of the Sectionalizing Circuit-breaker, ELEKTRO, Electrical engineering, electricity, electrical engineering **6**, 46–48 (2009)
- [2] L.D. Surov, V.V. Filippov, The control of Disconnection and Failure of Automatic Reclosing of the Main Switch of Line, Bulletin of Volgograd State Technical University **11**, 8, 88–91 (2014)
- [3] L.D. Surov, I.N. Fomin, V.F. Shumarin, The Control Method of the Shutdown and Successful Automatic Reclosing of the Sectionalizing Circuit-Breaker in the Ring Network Line, Applicant and patent holder FSEE HPE Orel State Agrarian University, Patent No. 2337453 Russian Federation IPC H02 J 13/00, No. 2007139420/09, declare 23.10.2007, publ. 27.10.2008, bul. no. **30**, 7 (2007)
- [4] L.D. Surov, I.N. Fomin, V.V. Grekov A Method for Controlling of a sectionalizing circuit-breaker in Case of a Failure to Open a Circuit-breaker of a Point of Automatic Transfer Switch Which has been Switched on for a Stable Short-circuit in a Ring Network, Applicant and patent holder FSEE HPE Orel State Agrarian University, Patent No. 2371826 Russian Federation IPC H02J 13/00, No. 2008138127/09, declare 24.09.2008, publ. 27.10.2009, bull. **30**, 6 (2008)
- [5] L.D. Surov, I.N. Fomin, N.V. Makhianova, Method of Control of Disconnection and Failure of Automatic Reclosing of the Sectionalizing Circuit-Breaker in the Ring Network Line, Patent of Russia No. 2304338, bull. **22** (2007)
- [6] I.N. Fomin, R.P. Belikov, Algorithm for Remote Control of the Head Switch Line, The Bulletin of Orel State Agrarian University, **61**, 4, 72–77 (2016)
- [7] L.D. Surov, I.N. Fomin, V.V. Grekov, A method for Monitoring the False Tripping of a Sectioning Switch in a Ring Network Line, Applicant and patent holder FSEE HPE Orel State Agrarian University, Patent No. 2378754 Russian Federation IPC H02J 13/00, No. 2008148640/09, declare 09.12.2008, publ. 10.01.2010, bull. **1**, 6 (2010)
- [8] L.D. Surov, V.V. Filippov, Determination of the Damaged Section of the Ring Network Line, Bulletin of the Volgograd State Technical University **8**, 187, 105–110 (2016)
- [9] N.S. Sorokin, Using of the Integrated Circuit FT232R chip AD7495AR and in a Block of Digital Processing in the System to Control The Operation of Electrical Networks 6-35 kV, Bulletin of Orel State Agrarian University **60**, 3, 87–93 (2016)
- [10] N.S. Sorokin, Improving the Efficiency of

Functioning of Electric Networks with Voltage of 6-35 kV by Monitoring the Parameters of the Electric Network, Scientific Bulletin of the National University of Bioresources and Environmental Management Ukraine. Series: Technique and Power Engineering of Agro-Industrial Complex **209**, 2, 92–95 (2015)

- [11] V.A. Chernyshov, E.A. Pechagin, The Remote Control of Overhead Transmission Lines with Insulated Neutral, Energy Conservation and Efficiency in Technical Systems, Proceedings of the IV International Scientific-Technical Conference of Students, Young Scientists and Specialists. Tambov State Technical University, 355–356 (2017)
- [12] I.N. Fomin, R. Belikov, V. Zelyukin, E.V. Mikhailova, Improvement of Power Supply Reliability by Means of Remote Control of the Automatic Repeated Switching-on of Sectionalizing Circuit-breakers, E3S Web of Conferences, 01042 (2019)
- [13] O.V. Naumov, Estimation Power Losses in Electric Devices of the Electrotechnical Complex, International Conference on Industrial Engineering, Applications and Manufacturing (ICIEAM), 6 coauth (2019)
- [14] O.V. Naumov, A.N. Gorlov, Influence of Value Resistance Contact Units of Switching Devices on Losses of the Electric Power in Low Voltage Shop Networks, IOP Conference, Materials Science and Engineering, 6 coauth (2019)