

Research and Development of Ship Waste Heat Driven S-CO₂ Power Generation Coupled T-CO₂ Refrigeration System

Min Li^{1,2*}, Yongqian Zhang¹, Youjian Wu¹, Ruitao Chen¹, Qianxi Zhang¹, Changming Ling^{1,2*}

¹Guangdong Ocean University, College of mechanical and power engineering, Guangdong Zhanjiang, 524088, China

²Guangdong Ocean University, Shenzhen Institute of Guangdong Ocean University, 518108, Guangdong Shenzhen, China

Abstract. Most of the exhaust temperature of ships is above 300°C, usually this part of waste heat would be directly discharged into the environment, not fully utilized. In order to improve the energy efficiency ratio of ship storage and transportation more effectively, domestic and foreign counterparts have done a lot of technical research on the recovery and utilization of ship waste heat, but most of them are based on a single application perspective. Emphasizing the application of multi-angle combined waste heat, driven by waste heat for CO₂ supercritical power generation coupling trans-critical refrigeration system was proposed and designed. While the combined system recovered waste heat for power generation, the functions of refrigerating cooling and seawater desalination were realized by using the properties of CO₂ working medium. Taking Fuyuan Yu 7861 ocean-going fishing boat as a design case, the relevant thermal calculation and equipment matching of CO₂ supercritical power-transcritical refrigeration system driven by waste heat recovery were targeted. The results showed that the total power consumption of the system is 34.171KW, the waste heat power generation efficiency is 12.9%, the refrigeration performance coefficient is 2.368, the energy saving effect is remarkable, and the energy saving and emission reduction are realized.

1 Introduction

In the working process of ship main engine, a lot of waste heat is generated, including diesel exhaust waste heat. In view of this situation, it is of great significance for energy conservation and environmental protection to use waste heat in a reasonable way. At present, the research on ship waste heat recovery technology mainly includes turbine system Rankine cycle seawater desalination, waste heat refrigeration and waste heat temperature difference power generation, etc. [1,2,3]. The existing waste heat power cycle mainly includes Organic Rankine cycle (ORC), organic trans-critical cycle (OTC), traditional steam Rankine cycle and other recycling waste heat power generation, but waste heat utilization rate and generation efficiency were not ideal. In the traditional steam Rankine cycle heat absorption process, the working medium and flue gas temperature changes are poorly matched, and the heat transfer temperature at narrow point is prominent. Therefore, in view of the heat emission characteristics of flue gas at medium and high temperature, it is very necessary to carry out the design of new power cycle, so as to break through the process research of waste heat efficiency.

In recent years, supercritical CO₂ (S-CO₂) had an important application in nuclear power, solar power and other fields as an alternative to steam power generation cycle. S-CO₂ Brayton cycle power generation technology has become a worldwide research hotspot. S-CO₂ cycle power generation technology has many

advantages and has attracted great attention in the field of civil and military (especially ships). The small size of the device is only 1/30 of the size of the steam power system, which makes the application of S-CO₂ Brayton cycle power generation technology in ships have unique advantages. The Brayton cycle of S-CO₂ is a closed cycle, which can be used for all kinds of heat sources of different temperatures, including low-quality fuel, coal, garbage burning geothermal energy, solar energy, industrial waste heat and other heat sources. Using the unique advantages of CO₂ to recover waste heat on the ship and combining with other functions of the auxiliary engine of the ship, to improve the waste heat efficiency and solve the needs of the cooling and heating system on the ship, and realize the integration of functions, would provide a good new direction for the design of the waste heat system of the new generation of ships.

A prominent problem in the application of S-CO₂ system is that its average discharge temperature is high. Reducing the average discharge temperature can improve the efficiency. Some scholars proposed some improvement measures to solve the problem that the average temperature of S-CO₂ exotherm was too high, such as re-compression of S-CO₂ or composite cycle [4,5]. Some scholars proposed a new solar power generation system using S-CO₂ and heat storage [6], and studies had shown that solar power generation system and conventional steam solar power generation system

* Corresponding author: lim@gdou.edu.cn, ling-cm@163.com

had significantly improved solar energy conversion efficiency. This provided a basis for the application of waste heat combined with other energy sources in the S-CO₂ system. Chacartegui R et al. [7] adopted CO₂ Brayton cycle, CO₂ transcritical cycle (T-CO₂), and T-CO₂/ORC for the solar power generation system. Zhang C et al. [8] proposed that the lower cycle should be the ORC and the upper cycle should be the composite cycle of three different power cycles, aiming at the exhaust residual heat of internal combustion engines, and concluded that the traditional steam Rankine cycle and ORC composite cycle had the highest thermal efficiency, which was illustrated from another aspect the compound circulation system using carbon dioxide as working medium had higher efficiency. Akbari A D et al. [9] studied the composite cycle of recompressing S-CO₂ and ORC, and the results showed that the thermal efficiency of re-compressing S-CO₂/ORC was 11.7% higher than that of re-compressing S-CO₂. In the dynamic recovery of flue gas waste heat, due to the approximate change of specific heat of CO₂ and flue gas, the heat exchange process would achieve a good match. As the exothermic process of flue gas heat source has great temperature variation characteristics, re-compression of S-CO₂ cannot be used to reduce the average exothermic temperature. The proposal of overinflation theory can solve this problem to a certain extent [10]. At present, developing new clean energy and improving the utilization efficiency of non-renewable energy are the key ways to realize sustainable development and solve the problem of energy shortage [11]. Domestic and

foreign experts were concerned about the performance improvement and efficiency of supercritical carbon dioxide power generation system for waste heat recovery [12]. Before entering into commercial application, the advantages and potential social and economic benefits of supercritical carbon dioxide cycle technology in various application scenarios were discussed and analyzed. By analyzing the characteristics and advantages of the S-CO₂ cycle, the feasibility of combining with various heat sources, such as fossil energy, nuclear energy, solar biomass waste heat, etc., was explored, and a variety of power generation system schemes were proposed to provide reference for the commercial application of the S-CO₂ cycle [13-15]. The purpose of this study is to improve the efficiency of ship waste heat utilization, in combination with other applications demand on ships, make full use of CO₂ as a working medium operation, at the same time of energy conservation and emissions reduction, the system is reduced and the utilization of the space ship is improved, to realize the coupling application of S-CO₂ power generation and cross-critical cooling. Research and analysis on the combined performance of supercritical power generation cycle and trans-critical refrigeration cycle with the help of CO₂[16]. The establishment of thermodynamic model and the analysis of power generation efficiency of the system, the cooling efficiency of the system, the seawater desalination under specific working conditions, which integrates the ship waste heat and the functions of the auxiliary engine provide a new way of thinking.

2 System design

Schematic diagram of S-CO₂ power generation system driven by ship waste heat and T-CO₂ refrigeration system is shown in Figure 1.

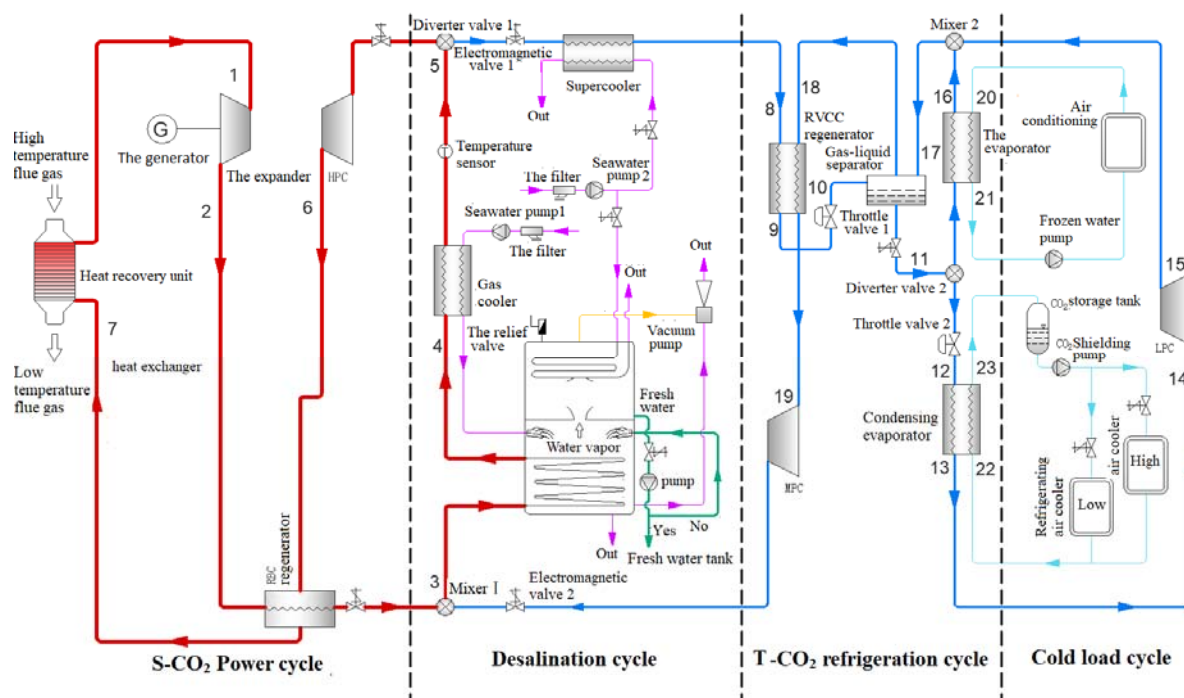

Fig. 1 Schematic diagram of coupling between the ship waste heat driven S-CO₂ power generation and T-CO₂ refrigeration system

As shown in Figure 1, this system is composed of four parts.

S-CO₂ power generation cycle: CO₂ is heated through flue gas heat collector to recover waste heat, and the S-CO₂ gas with high temperature and pressure enters the expander to do expansion work and generate electricity. The CO₂ gas from the expander is cooled in the generating cycle regenerator (RBC regenerator) and mixed with the gas from the refrigeration system through the medium pressure compressor (MPC) into the seawater desalination heat exchanger in the vacuum flash tank after mixing in Mixer 1. After passing through the gas cooler and passing through the shunt valve 1, it is absorbed by the high-pressure compressor (HPC) and compressed to the high pressure state. After being heated by the generation cycle regenerator (RBC regenerator), it returns to the flue gas heat regenerator to absorb the flue gas heat and recover the waste heat, thus completing a S-CO₂ generation cycle.

T-CO₂ refrigeration cycle: The CO₂ gas compressed by the medium pressure compressor (MPC) is mixed by Mixer 1 with the CO₂ fluid from the supercritical power generation system and then goes to the seawater desalination heat exchanger in the vacuum flash tank. After cooling through the gas cooler, the flow is divided into the flow of the cross-critical refrigeration system through the shunt valve 1, and then the flow goes through the cooler and into the refrigeration cycle regenerator for further supercooling. Simultaneously, it conducts heat exchange with the gas discharged from the gas-liquid separator. After supercooling, the gas is cooling and depressurization by throttling through the expansion valve 1. The pressure drops from medium pressure (8.8MPa) to low pressure (3.97MPa) and enters the gas-liquid separator. The gaseous CO₂ is mixed with the gas discharged from the high temperature evaporator and enters the refrigeration cycle regenerator. Liquid phase CO₂ flows from the lower end of gas-liquid separator through shunt 2 and is divided into two streams of fluid, one of which enters into high-temperature evaporator to evaporate and refrigerate, resulting in refrigeration effect. The resulting amount of cooling is transferred to the water secondary refrigerant of air conditioning is used to cool the end surface of the air conditioning system. The other CO₂ liquid passes through the expansion valve 2 to reduce the temperature and pressure again, and the pressure drops from low pressure (3.97Mpa) to even lower pressure (2.29Mpa), and enters the evaporative condenser for evaporative refrigeration. The amount of cooling produced is transferred to the CO₂ secondary refrigerant system and provide cooling for the CO₂ air cooler for freezing and CO₂ air cooler for cold storage. At the same time, the low temperature and low pressure CO₂ gas of heat gasification in the low temperature condensing evaporator is sucked and compressed by the low pressure compressor (LPC). The gas discharged from LPC is then mixed with the gas discharged from the high temperature

evaporator by mixer 2 and enters the gas-liquid separator. The gas CO₂ from the gas-liquid separator enters the refrigeration cycle regenerator to absorb heat. After absorbing heat from the refrigeration cycle regenerator, the gas is inhaled and compressed by the medium-pressure compressor (MPC) to the medium-pressure pressure and then discharged, completing a T-CO₂ refrigeration cycle. Among them, the seawater of the cooling medium in the supercooler adopts the form of wastewater direct discharge. In other words, the seawater outside the tank is pumped into the supercooler by seawater pump 2, after heat transfer through the heat exchanger, it is directly discharged out of the tank to realize direct cooling.

In this design, the taking cold system is divided into two parts: the high temperature taking cold system part uses water as the secondary refrigerant, and the low temperature taking cold system part uses CO₂ as the secondary refrigerant.

(1) High-temperature water- taking cold system: In the high temperature evaporator, the CO₂ refrigerant liquid is vaporized and absorbs the heat of the secondary refrigerant water, so that the heat of the secondary refrigerant water is released to produce the frozen water. The chilled water is transported to the end surface cooler of the air-conditioning system by the chilled water pump, and the chilled water after releasing the cold quantity returns to the high-temperature evaporator for heat release. Complete a water-borne cooling cycle.

(2) Low temperature CO₂-taking cold system: In the condensing evaporator, the CO₂ refrigerant liquid gasification absorbs a lot of heat and condenses the CO₂ secondary refrigerant from the gas to the liquid state. Then the secondary refrigerant CO₂ liquid enters the CO₂ reservoir at the taking cold cycle, which is delivered to the CO₂ cooler for freezing and the CO₂ cooler for cold storage by CO₂ shielded pump. The CO₂ gas gasified in freezing and cold storage is condensed again into the condensing evaporator, to complete a CO₂-borne cooling cycle.

Seawater desalination system cycle: The seawater is filtered by the sea water filter and pumped into the gas cooler by sea water pump 1 for heat exchange. The preheating temperature of the sea water reaches 60°C. Then into the vacuum flash tank through the serrated edge chute and the sea water is evenly dispersed. The jet evaporates after being heated by a desalination heat exchanger. Seawater is heated in a vacuum to produce water vapor continuously. The water vapor ascends into the upper space of the vacuum flash tank by convection, and releases heat through a steam condenser and condenses into fresh water. Fresh water drips naturally into the temporary storage tank under the action of gravity and is pumped out by the fresh water pump. Some of the strong brine is discharged out of the tank by a salt discharge pump. The seawater provided for cooling in the steam condensers is in the form of direct discharge of wastewater.

3 Application of design principles and calculation examples

In order to verify the feasibility of the design scheme and principle, taking the ocean-going fishing vessel of a certain capacity as the calculation condition, the surplus heat of the fishing vessel and the matching calculation of corresponding system and equipment were carried out. The basic parameters of ocean-going fishing vessels are shown in Table 1.

Table 1 Basic parameters of ocean-going fishing vessels

The tenth of the hull/m	50.3	
The width of the hull/m	8.6	
Dead weight capacity/t	340	
Designed draft /m	3.50	
Operating speed/m/s	15.6	
Main motor power /kW	1000	LB6250ZLC-20 four-stroke
Produce fresh water/(t/h)	0.1	Fresh water machine 2.5t/d t/d
	m ³ /s	
Cold storage load/kW	30KW	-6°C
High temperature load/kW	25KW	5°C
Air conditioning load/kW	40KW	10°C chilled water
Discharge Temperature/°C	325°C	Below 80% load
Flue gas discharge capacity/kg/s	1.602m ³ /s	Below 80% load

3.1. Selection of relevant design parameters

3.1.1 Selection of seawater parameters

The temperature of seawater was 25°C, standard seawater and the salinity was 35‰ with a chlorinity of 19.38‰[17]. Mean specific heat capacity of seawater is cp=4.013 kJ/kg.

3.1.2 Selection of seawater flash evaporation temperature

Comprehensively considering the vacuum pump working pressure and seawater flash temperature too high would cause scaling problem. Meanwhile, seawater flash evaporation temperature is limited by heat source (CO₂ working medium cooling heat) temperature and pinch temperature difference. The selected flash temperature ts=60°C and the corresponding vacuum tank pressure is 19.919kPa[18].

3.2 Thermodynamic calculation of system circulation

Place the figure as close as possible after the point where it is first referenced in the text. If there is a large number of figures and tables it might be necessary to place some before their text citation. If a figure or table is too large

to fit into one column, it can be centred across both columns at the top or the bottom of the page.

3.2.1 Description and analysis of the system

The S- CO₂ Brayton cycle is a closed loop power generation cycle. Both compression and expansion occur entirely in the gas phase. And both the circulating high and low pressures remain above the CO₂ critical point. The circulation system is composed of five main parts, such as expander, compressor, regenerator, gas cooler, flue gas heat regenerator, etc. According to the selected parameter conditions, the corresponding pressure-enthalpy diagram is shown in Figure 2.

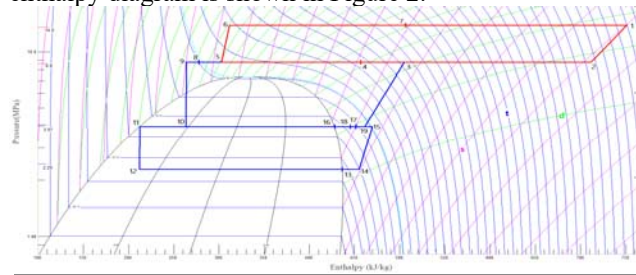

Fig. 2 Pressure enthalpy diagram of the system

The process of S-CO₂ cycle is shown in the state point 1-2-3-4-5-6-7-1 on the pressure enthalpy diagram in Fig. 2. The process description is shown in Table 2.

Table 2 Process description table of S-CO₂ cycle

Process	State point description
1-2	State point 1 (14Mpa/310°C) CO ₂ expanded to the state point 2 (8.8 Mpa/265.3°C) in the expander. Simultaneously, driving a generator to generate electricity.
2-3	The state point 2 (8.8Mpa/265.3°C) CO ₂ was cooled to the state point 3 (8.8Mpa/94.1°C) in the RBC regenerator. Simultaneously heat HPC exhaust, confluence with CO ₂ of refrigeration cycle.
3-4	State point 3 (8.8Mpa/94.1°C) CO ₂ was cooled by a seawater desalination heat exchanger to state point 4 (8.8Mpa/65.5°C) . Meanwhile, heat the seawater to evaporate.
4-5	State point 4 (8.8Mpa/65.5°C) CO ₂ was cooled by the gas cooler to the state point5 (8.8Mpa/35°C) , simultaneous preheating of seawater.
5-6	State point 5 (8.8Mpa/35°C) CO ₂ being shunted, part was inhaled by HPC. Compressed to state point 6 (14Mpa/47.6°C) .
6-7	State point 6 (14Mpa/47.6°C) CO ₂ was heated by the RBC regenerator to the state point 7 (14Mpa/120.5°C) , at the same time cooling expander exhaust.
7-1	State point 7 (14Mpa/120.5°C) CO ₂ was heated back to the state point 1 (14Mpa/310°C) by the heat collector, simultaneously cooling the diesel exhaust, Completed a cycle.

The T- CO₂ vapor compression cycle is a closed loop refrigeration cycle, the compression process took place in the supercritical region (gas phase). The throttling and evaporation processes occur in the subcritical zone (liquid and gas phase two phase zone), and the evaporation pressure of the refrigeration cycle is

guaranteed below the critical point. The refrigeration circulation system consists of medium pressure compressor, low pressure compressor, gas cooler, supercooler, regenerator, gas-liquid separator, expansion valve, evaporative condenser, high temperature evaporator and other main components as Fig. 1. The thermodynamic process is shown in Figure 2. The state points of 3-4-5-8-9-10-16-18-17-19-3 and 15-19-17-18-12-13-14-15 on the pressure enthalpy chart, the process description is shown in Table 3.

Table 3 Process description of T-CO₂ refrigeration cycle

Process	State point description
5-8	State point 5 (8.8Mpa/35°C) CO ₂ cooled and condensed to state point 8 (8.8Mpa/30°C) by the cooler, the CO ₂ gas was condensed into liquid.
8-9	State point 8 (8.8Mpa/30°C) was cooled to State point 9 (8.8Mpa/26°C) in the RVCC regenerator. At the same time, the gas from the hydrothermal separator was further added.
9-10	State point 9 (8.8Mpa/26°C) CO ₂ reduced temperature and pressure through expansion valve 1 to state point 10 (3.97Mpa/5°C), formed CO ₂ two phase refrigerant.
11-16	State point 11 (3.97Mpa/5°C) CO ₂ liquid went into the evaporator, evaporating to state point 16 (3.97Mpa/5°C) in evaporator, and cooling air conditioning circulation frozen water.
11-12	State point 11 (3.97Mpa/5°C) CO ₂ reduced temperature and pressure through expansion valve 2 to state point 12 (2.29Mpa/-15°C), formed CO ₂ two phase refrigerant.
12-13	State point 12 (2.29Mpa/-15°C) CO ₂ liquid went into the evaporative condenser evaporating to state point 13 (2.29Mpa/-15°C), and condensing the secondary refrigerant CO ₂ .
14-15	State point 14 (2.29Mpa/-10°C) CO ₂ was sucked into the LPC temperature rise and boosted to state point 15 (3.97Mpa/31.9°C)
18-19	State point 18 (3.97Mpa/15.2°C) CO ₂ was heated to state point 19 (3.97Mpa/25.3°C) in the RVCC regenerator, and further supercooled supercooler discharge CO ₂ .
19-3	State point 19 (3.97Mpa/25.3°C) CO ₂ was sucked into the MPC to heat up and boost pressure to State point 3 (8.8Mpa/94.1°C), and confluenced with CO ₂ from power generation cycle.

3.2.2 Selection and calculation of parameters at each state point of the system cycle

As can be seen from the pressure-enthalpy diagram, the physical property of CO₂ changes dramatically when it is near the critical point, but it tends to moderate when it is far from the critical point. Considering the stability and economy of the system [19], 14Mpa~ 8.8Mpa was selected as the maximum and minimum pressure of S-CO₂ power generation cycle. Simultaneously, the system temperature was limited by the diesel exhaust and cooling seawater temperature, 310~35°C was selected as the highest - lowest temperature range of the power generation cycle. The evaporation pressure across the critical refrigeration cycle was determined by the

evaporation temperature. Evaporator temperature $T_{eva1} = 5^{\circ}\text{C}$, pressure $P_{eva1} = 3.97\text{Mpa}$; Temperature of evaporative condenser $T_{eva2} = -15^{\circ}\text{C}$, pressure $P_{eva2} = 2.29\text{Mpa}$.

3.3 Thermal calculation of relevant systems

The corresponding parameter correlation values of CO₂ supercritical power generation and cross-critical refrigeration are shown in Table 4, and the calculation results of expander and compressor in the system are shown in Table 5.

Table 4 Summary of circulating working medium parameters

Point	p [Mpa]	t [°C]	h [kJ/kg]	s [kJ/(kg.K)]	v [m ³ /kg]	Phase
1	14	310.00	751.49	2.4023	7.64E-03	Supercritical
2s	8.8	259.13	704.38	2.4023	1.10E-02	Supercritical
2	8.8	265.34	711.45	2.4155	1.11E-02	Supercritical
3s	8.8	89.57	498.60	1.9333	5.86E-03	Supercritical
3	8.8	94.05	505.21	1.9514	6.04E-03	Supercritical
4	8.8	65.48	457.68	1.8164	4.74E-03	Supercritical
5	8.8	35.00	302.14	1.3272	1.55E-03	Supercritical
6s	14	47.18	309.83	1.3272	1.43E-03	Supercritical
6	14	47.61	311.19	1.3314	1.44E-03	Supercritical
7	14	120.46	507.11	1.8907	3.91E-03	Supercritical
8	8.8	30.00	277.52	1.2467	1.36E-03	Liquid
9	8.8	26.00	263.14	1.1990	1.27E-03	Liquid
10	3.97	5.01	263.14	1.2255	2.91E-03	2-Phase
11	3.97	5.01	212.52	1.0435	1.12E-03	Saturated liquid
12	2.29	-15.01	212.52	1.0570	3.69E-03	2-Phase
13	2.29	-15.01	436.28	1.9238	1.65E-02	Gas
14	2.29	-10.00	442.99	1.9495	1.72E-02	Gas
15s	3.97	28.82	465.98	1.9495	1.12E-02	Gas
15	3.97	31.86	470.04	1.9629	1.14E-02	Gas
16	3.97	5.01	427.48	1.8163	8.72E-03	Saturated gas
17	3.97	18.80	451.70	1.9003	1.03E-02	Gas
18	3.97	15.15	446.00	1.8817	9.90E-03	Gas
19	3.97	25.29	461.13	1.9333	1.09E-02	Gas

Note: The subscript s in the above table indicates the thermodynamic parameters of the working medium in the ideal state.

Table 5 Calculation parameters summary expander/compressor

Equipment Name	Theoretical capacity of equipment/ (m ³ /h)	Actual capacity of equipment	Power/ (kW)
----------------	--	------------------------------	-------------

		/(m ³ /h)		
Expansion machine	31.39	23.54	28.39	
High pressure compressor	6.12	4.77	9.39	
Medium pressure compressor	36.87	23.23	31.66	
Low pressure compressor	23.23	16.03	8.45	

The selection and calculation of relevant equipment parameters of seawater desalination system are shown in Table 6. The heat load and the area calculation results of the heat exchanger in the system are shown in Table 7.

Table 6 Calculation parameters of seawater desalination

Names of things	Parameter	Names of things	Parameter
The amount of inn seawater	5.50	Vacuum tank pressure /kPa	19.919
$q_{min}/t/h$		Flash seawater temperature /°C	60
Concentrated seawater displacement	5.40	Latent heat of water at 60°C	2358.4
$q_{mout}/t/h$		r/kJ/kg	
Fresh water generating capacity	0.1	Inlet temperature of steam generator $t_3/°C$	94.05
m/t/h		Steam generator outlet temperature $t_4/°C$	65.48
Initial temperature of seawater /°C	25		
Specific heat of seawater	4.013		
$C_p/kJ/(kg.k)$			

Table 7 Heat load parameters of heat exchanger

Heat exchanger	Heat load /kW	Matching area/m ²	Heat exchanger	Heat load /kW	Matching area/m ²
Gas cooler	214.40	19.61	RBC regenerator	261.76	41.60
subcooler	15.41	2.22	Heat recovery Unit	209.26	74.37
evaporator	42.11	4.20	Flash heat exchanger	68.96	2.03
Evaporative condenser	57.89	18.19	Vapor condenser	62.24	1.35
RVCC regenerator	9.01	18.77			

Simultaneously, calculating the volume flow of each pump: sea water pump I is 5.36 m³/h, sea water pump 2 is 6.33 m³/h, condensated water pump is 2.20 m³/h.

3.4 Thermal calculation and equipment selection of load cooling system

Basic parameters of load cooling system, the cooling load of refrigerated storage and high temperature refrigerated storage is 25kW and 40kW respectively. CO₂ was used as secondary refrigerant, and the load cooling temperature was -6°C and 5°C respectively. Calculating total volume flow of the secondary

refrigerant CO₂ was 0.779 m³/h. The cooling load of air conditioner is 40kW, water was used as secondary refrigerant, and the load cooling temperature was 10°C. Calculating the volume flow of the secondary refrigerant water was 6.84 m³/h.

3.5 Design and calculation of flash evaporator

As shown in Table 7, the heat transfer area of the steam generator is 2.03 m², and the area of the steam condenser is 1.35 m². This system used the most commonly used vacuum distillation seawater desalination device on board [21]. Recovering heat from the CO₂ cycle was supplied to the steam generator. Using seawater took away the heat released from steam condenser. The waste heat of the gas cooler was also used to preheat the seawater that needed desalination. In order to make the device more compact, a new flash tank was designed as Fig.3.

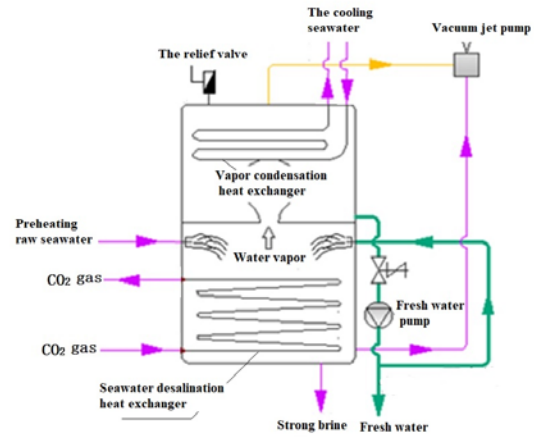

Fig.3 Schematic diagram of flash tank design

The new flash tank is divided into two parts, the lower part is the evaporation chamber and the upper part is the condensation chamber. The middle is connected by a nozzle type channel. The clapboard separates the two chambers and acts as a temporary storage tank for condensed fresh water. The condensate pump opens periodically according to the fresh water volume of the temporary storage tank to deliver the fresh water boost to the fresh water tank.

The upper part of the flash tank is arranged with a condensing heat exchanger and connected with a vacuum pump, which maintains the pressure in the tank below 19.919 kPa, and can ensure the raw seawater in the evaporation room to flash steam at 60°C. The water vapor enters the condensing chamber through the nozzle type passage and is quickly condensed into fresh water. It is then drained by the needle rib into the temporary storage tank. In order to reduce the pump power consumption, the concentrated seawater at the bottom of the evaporation chamber is directly referenced as the water ejected by the water jet pump. Selection of jet vacuum pump is PSB-40, swept volume 40 m³ / h.

3.6 Energy consumption analysis

Based on the above calculation results, the combined designed system had a total power consumption of 26.021kW and a cooling capacity of 95kW. The fresh water consumption was 8.15kW, and the fresh water production was 2.4t/d. Total flue gas residual heat collection was 220.28kW. When the cooling capacity and fresh water requirements of the system were met, the total power consumption of the system was 34.171kW, the power generation efficiency was 12.9%, the refrigeration coefficient of performance was 2.368. So the energy saving effect is significant.

4 Comprehensive analysis and conclusion

1) Utilizing the combination of properties of CO₂, the waste heat driven S-CO₂ power generation cycle coupling T-CO₂ refrigeration cycle system was designed, which integrated to realize the on-board power generation, cooling and seawater desalination. It greatly saved the space occupied by auxiliary engines and improved the utilization rate of hull space. The multi-stage utilization of waste heat maximizes the utilization of waste heat. Simultaneously, the exhaust temperature of diesel engine was lowered to realize energy saving and emission reduction.

2) Design and matching of new vacuum flash tank made the flash desalination plant more energy-saving and compact, and had better use efficiency.

3) The design system had good flexible performance. The CO₂ power generation cycle and refrigeration cycle can run simultaneously or separately. The engine works normally while the ship is sailing, and the two systems run simultaneously, which realize power generation, refrigeration and desalination. When the ship stops, the engine stops, and the refrigeration system runs independently to realize refrigeration and desalination, and keep the air-conditioned and food refrigerated. When the refrigerating heat load is low and the power consumption is low, the net output power can compensate the power consumption equipment outside the system. The thermal calculation and equipment matching results of a fishing boat with a certain capacity of waste heat showed that the design can be implemented.

Acknowledgement

The authors acknowledged the financial support from the Science and Technology Project of Zhanjiang City (No. 2019A01043), Shenzhen Science and Technology Innovation Committee providing the research project (JCYJ20170818111558146).

References

1. Z. Dou, C. Yang. *Energy Conservation & Environmental Protection in Transportation*, 14(03), 19-22(2018).

2. S. Wang, R. Wang. *China ship repairing*, 3, 25-27(2003).
3. B. Wang, X. Song. *Mechanical Engineer*, 3, 6-8+11(2018).
4. C. Duan, J. Wang, X. Yang, M. Ding, J. Cao. *Nuclear Power Engineering*, 31(06), 64-69(2010).
5. C. Deng, J. Wang, X. Yang. *Atomic Energy Science and Technology*, 44(11):1341-1348(2010).
6. J. Liu, H. Chen, Y. Xu, L. Wang, C. Tan. *Renewable Energy*, 64(1), 43-51(2014).
7. R. CHACARTEGUI, J.M. M. D. ESCALONA, S. NCHEZ D. *Applied Thermal Engineering*, 31(5), 872-879(2011).
8. C. Zhang, G. Shu, H. Tian, et al. *Energy Conversion & Management*, 89(1), 541-554(2015).
9. S. S. MAHMOUDI, A. D. AKBARI, M. ROSEN. *Sustainability*, 8(10), 1079(2016).
10. H. Chu, X. Wang, C. Li, H. Wang. *CHEMICAL ENGINEERING (CHINA)*, 45(12): 6-10(2017).
11. Y. Zhao, Z. Dong, Y. Zhang, J. Zhao. *Journal of Engineering for Thermal Energy and Power*. 34(01), 11-16(2019).
12. K. Zhen. *Power Generation Technology*, 39(02), 33-39(2018).
13. M. Benjelloun, G. Douglgeris, R. A. Singh. *J. Power and Energy*, 226, 372-383(2011).
14. X. Zhanga, H. Raguchia, D. Yamenoa, K. Fujimab, M. Enomotoc, N. Sawada. *Renewable Energy*, 31, 1839-1854(2006).
15. P. Kumar, K. Srinivasan. *Applied Thermal Engineering*, 109, 831-840(2016).
16. K. Manjunath. *Energy Conversion and Management*, 155, 262-275(2018).
17. G. Yuan, editor-in-chief. *Seawater desalination engineering design*, Beijing, China Electric Power Press(2013).
18. S. Lang. *Dalian University of Technology*, 2019.
19. S. Hou. *Harbin Engineering University*, 2016.
20. H. Zhang, H. Li, Y. Wu. *Refrigeration Compressor 3rd edition*, Beijing, China Machine Press(2018).
21. G. Liu, J. Chen, G. Li. *Ship & Ocean Engineering*, 38(06), 43-45(2009).