

# Design and Modelling of Technologies for Upgrading and Direct Methanation of biogas: energy analysis and economic assessment

Alessandra Perna<sup>1</sup>, Mariagiovanna Minutillo<sup>2</sup>, and Alessandro Sorce<sup>3\*</sup>

<sup>1</sup>University of Cassino and Southern Lazio, Department of Civil and Mechanical Engineering, 30043 Cassino, Italy

<sup>2</sup>University of Naples "Parthenope", Department of Engineering Centro Direzionale Isola C4, 80143 Naples, Italy

<sup>3</sup>University of Genoa, Thermochemical Power Group, Via Balbi 5, 16124, Genoa, Italy

**Abstract.** The exploitation of the biomethane as transport fuel is receiving increasing attention in many European countries. Technologies and processes for improving the Biogas-to-biomethane production with a lower energy consumption and lower costs are objective of several techno-economic studies.

In this paper two promising concepts for the biogas conversion are proposed and analyzed considering both technical and economic issues. The analysis regards the biogas upgrading by means of the chemical absorption with Hot Potassium Carbonate and the direct methanation of biogas by adding renewable hydrogen. In order to assess the feasibility of these technologies the numerical modelling has been applied for the plants designing. The energy results have then been used to assess the expected biomethane production price and a sensitivity analysis on the main parameters has been performed. Finally, economic performance of the options proposed will be evaluated under different market conditions.

## 1 Introduction

Biogas produced from biomass is considered a promising solution for biofuels production [1,2]. According to the feedstock and the biogas production technology, the methane content can range between 45-65% and the main contaminant is CO<sub>2</sub>. Thus, through upgrading processes it is possible to produce biomethane for transportation purpose or for its exportation to the gas grid.

The methods for upgrading biogas to biomethane is divided into two categories:

- a) Biogas upgrading by removal of the CO<sub>2</sub> fraction by means of physical or chemical processes;
- b) Direct methanation of biogas by reacting the CO<sub>2</sub> fraction with hydrogen from another source.

These methods mainly differ for the efficiency in the methane production and for the investment costs.

Obtaining biomethane from an upgrading process is the simplest approach thanks to a lower plant complexity and lower costs.

Producing biomethane by combining hydrogen produced via electrolysis and biogas is a promising approach that allows to increase the production of CO<sub>2</sub>-neutral fuel. Moreover, if the hydrogen is produced by using fluctuating and intermittent renewable sources this approach can be considered as an application of the "power to gas", PtG, strategy for the indirect storage of

excess electricity production from fluctuating sources. As a matter of fact, the synthesis of methane through methanation can strongly contribute to large scale energy storage, as CH<sub>4</sub> injection is not limited in the gas grid [3].

This paper is focused on the energy and economic analysis of these methods through the designing and modelling of two plants configurations: the biogas to methane (B2M) plant via upgrading process and biogas and hydrogen to methane (BH2M) plant via direct methanation.

## 2 Design and Modelling of Biomethane production plants

Figure 1 shows the two options for the biomethane production proposed in this work. The biomethane can be obtained by upgrading the biogas in the B2M plant configuration via CO<sub>2</sub> removal or by direct biogas methanation with hydrogen via electrolysis in the BH2M plant configuration. The comparison is made maintaining the same input of processed biogas flow rate equal to 500 Nm<sup>3</sup>/h. The electric energy requirements of the plants are satisfied by the electric grid in the B2M plant and by an electricity mix between the renewable sources (RES) and the electric grid in the BH2M plant. In both the layouts the non-methane

\* Corresponding author: [alessandro.sorce@unige.it](mailto:alessandro.sorce@unige.it)

gaseous streams produced, respectively CO<sub>2</sub> and O<sub>2</sub>, are released to the environment. The energy analysis and the sizing of the plants have been carried out exploiting thermo-chemical models developed in Aspen Plus environment. In order to evaluate the cost of the produced biomethane in the proposed plant an economic analysis has been carried out.

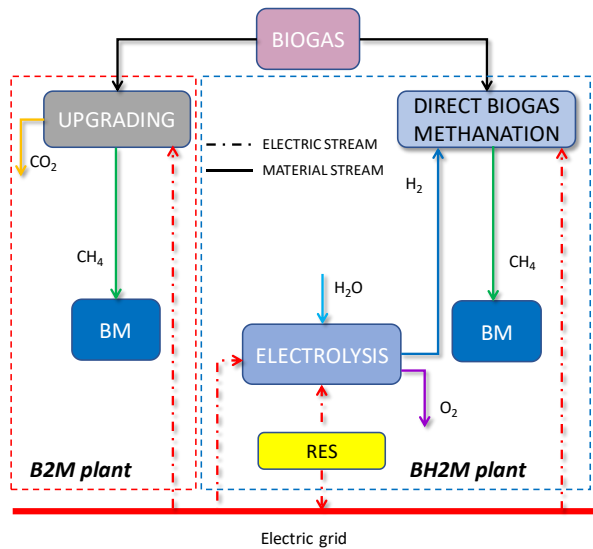

**Fig. 1.** Biogas to Methane options with upgrading and direct methanation

## 2.1 Biogas to Methane plant via CO<sub>2</sub> removal

The biogas upgrading process selected for obtaining the biomethane is based on the Hot Potassium Carbonate (HPC) technology [4]; as a matter of fact, K<sub>2</sub>CO<sub>3</sub> solution is an interesting option for realizing the biogas upgrading from the environmental hazard point of view.

The HPC system is based on an absorption process and on a regenerative process that are carried out in two specific columns.

In the absorption column, the reaction of the potassium carbonate solution with CO<sub>2</sub> takes place:

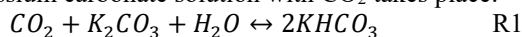

The absorption heat is -44 kJ/mol CO<sub>2</sub> and the operating pressure is 8 bar.

In the stripping column, operating at atmospheric pressure, the chemical bond formed in the absorber is disrupted and the CO<sub>2</sub> is separated from the potassium carbonate (this is the regenerative phase).

The HPC system has been modelled by following the numerical approach presented in ref. [4]. ELECRTL has been used as the physical property method.

Figure 2 shows the flowsheet of the model. The biogas (1) is compressed at 8 bar and mixed with the recirculated stream (10) coming out from the flash unit.

This mixture (3) is cooled at 35°C (4) before entering in the absorber. The solution coming out from the bottom of the column is sent to the flash unit operating at 5 bar.

From the top of the absorber column the biomethane (5) exits at 68°C and, after the water condensation, its concentration is 98.5 vol.% (6).

The stream (9) from the flash unit enters the stripping column where the HPC solution is regenerated.

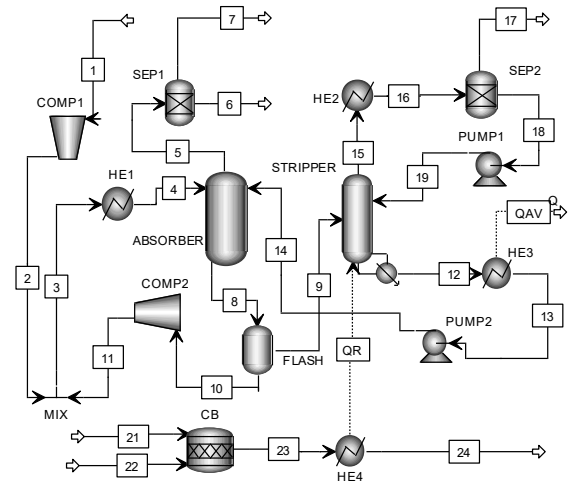

**Fig. 2.** Flowsheet of the B2M plant model

From the stripping column two streams go out: a mixture of water and CO<sub>2</sub> (15), that exits from the top of the column at 87°C, and the HPC solution, that comes out from the bottom of the column at 106°C (12). This solution is cooled in HE3 (68°C) and is pumped to the absorber (14). The available thermal power (Q<sub>av</sub>) can be supplied to the digester. The boilup ratio of the stripper is assumed equal to 0.072 and heat (Q<sub>R</sub>), required for producing the necessary steam for the process and for disrupting the chemical bond formed in the absorber, is supplied by a catalytic burner (CB) and results equal to 353 kW.

Finally, in the sep2 the CO<sub>2</sub> stream is split: the stream (17), the separated CO<sub>2</sub>, is vented out in the atmosphere and the stream (18) is recirculated to the stripper (the CO<sub>2</sub> recirculation is 35%).

## 2.2 Biogas to Methane plant via direct methanation

The BH2M plant can be considered as a PtG plant in which the biogas is directly used as feedstock for CO<sub>2</sub> methanation, as CH<sub>4</sub> content in the biogas has only a little influence on the Sabatier reaction at high pressure. In order to assure a continuous operation, it is assumed that the energy requirements for the electrolysis and the BoP are satisfied by the RES, when available, or by the electricity from the grid. The flowsheet of the BH2M plant is depicted in figure 3.

The electrolysis unit is based on PEM technology whereas in the methanation unit an isothermal multi-tube packed bed reactor cooled by boiling water is used. The reactor design is a double pass with condensate removal after the first pass as described in ref. [3]. This double pass strategy ensures a methane content/Wobbe index within the specifications of natural gas.

The biogas (1) is compressed up to the methanation pressure (20 bar) in C1 and mixed with the stored hydrogen (16) before entering the methanation reactor operating at 280°C (the conversion is favoured by a reactor temperature in the range 250–300 °C). After the first pass, the produced water is partially removed by

condensation before the gas is passed through the second reactor tube (5). Finally, the product syngas is sent to a separator for water removal.

The isothermal reactor is modelled by using two *RGibbs* reactors (the chemical equilibrium is assumed), one per pass and a flash drum operation block. The reactor cooling is performed by means of a heat mixer block and a *Heater* block in which the boiling water is generated at 65 bar. The model of the isothermal methanation reactor has been validated by using the experimental data reported in ref. [3].

The PEM electrolysis unit is modelled by means of a *RStoich* operation block where the water decomposition takes place and a separator operation block. Mixers and splitters are also used for accounting of the water utilization factor in the anode side. The electrochemical behaviour of the electrolysis module is simulated by means of a Fortran calculator block in which the polarization curve of each stack is derived by fitting the experimental data of a 3-cells stack reported in [4] and operating at 20 bar and 54°C.

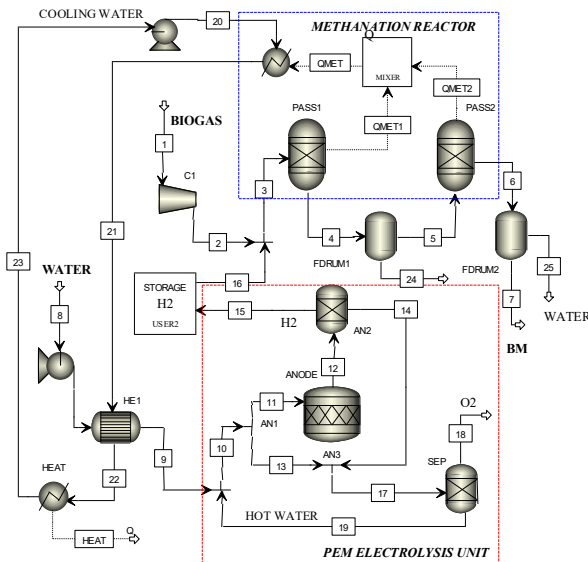

**Fig. 3.** Flowsheet of the BH2M plant model

A hydrogen storage unit at 20 bar is also considered in order to decouple the electrolysis unit operation from that of the methanation unit. The storage unit is sized to cover 6 hours of biomethane production. Table 1 shows the main operating data of the proposed plant.

The Peng-Robinson (PR) equation of state was selected for the simulation, as this approach is widely accepted in the systems containing hydrocarbons and related compounds and hydrogen in a wide range of pressure and temperature.

By starting from the biogas plant capacity (about 500 Nm<sup>3</sup>/h), the electrolysis unit (4 MW) is sized to supply the hydrogen flow rate required to valorise 200 Nm<sup>3</sup>/h of CO<sub>2</sub>. At rated power the LHV system efficiency is 55.7 (5.48 kWh/Nm<sup>3</sup> of hydrogen or 59.8 kWh/kg of hydrogen).

The cooling water of the methanation reactor is used for heating the feeding water (HE1) of the electrolysis unit and for cogeneration purpose (thermal power HEAT).

**Table 1.** Main operating data of BH2M plant

Section/Component	
<i>Compressor C1</i>	
Pressure ratio	20
Polytropic efficiency	0.85
<i>Methanation reactor</i>	
Pressure (bar)	20
Temperature (°C)	280
CO <sub>2</sub> /H <sub>2</sub>	4
<i>Electrolysis Unit</i>	
Modules	2
Stacks number x module/ Cells number x stack	3/100
Active cell area (cm <sup>2</sup> )	1000
Pressure/temperature (bar/°C)	20/55
Average Cellvoltage/Current density (V/Acm <sup>-2</sup> )	2.17/2.99

### 2.3 Performances estimation and comparison

In the B2M plant the composition (vol%) of the produced biomethane is CH<sub>4</sub> 98.5, H<sub>2</sub>O 1.4, CO<sub>2</sub> 0.1, the Wobbe Index (WI) is 48.81 MJ/Sm<sup>3</sup> and the LHV is 49.1 MJ/kg. In the BH2M plant the resulting biomethane composition is CH<sub>4</sub> 97.0, H<sub>2</sub> 0.5, CO<sub>2</sub> 2.3, H<sub>2</sub>O 0.2, whereas the WI and the LHV are equal to 47.37 MJ/Sm<sup>3</sup> and 46.9 MJ/kg, respectively.

The plant efficiency based on the energy balance is defined as the ratio between the output energy stream (biomethane) and the input energy streams (biogas, electricity) [4]:

$$\eta_{plant} = \frac{\Phi_{BM}}{(\Phi_{biogas} + P_{el})} \quad (1)$$

The mass and energy balances of the plants are summarized in table 2. The methanation of the CO<sub>2</sub> allows to increase the biomethane production of about 71%, but the electric consumption in the BH2M configuration is very high due to the PEMEL energy requirements. This involves that the efficiency of the B2M plant is 19 percentage points higher than that of the BH2M one.

**Table 2.** Mass and energy balance

Plant Configuration	B2M	BH2M
<i>Mass streams (kg/h)</i>		
Biogas to the process	610	610
Biogas to the catalytic burner	78	-
Hydrogen to methanation unit	-	67.2
Water to electrolysis unit	-	603
HPC solution (30 wt. % K <sub>2</sub> CO <sub>3</sub> )	7750	-
Oxygen	-	268
Carbon dioxide	387.3	-
Biomethane	216.3	369.5
<i>Power balance (MW)</i>		
Biomethane production (MW <sub>LHV</sub> )	2.95	4.81
Available thermal power (MW)	0.201	0.154
PEMEL power consumption (MW)	-	4.03
BoP power consumption (MW)	0.081	0.087
<i>Efficiency</i>		
Plant efficiency	87%	68%

### 3 Economic assessment

The economic assessment has been performed by calculating the Capital Expenditure (CAPEX), the Operational and Maintenance costs (O&M) and the Replacement costs in order to assess the levelized cost of biomethane (LCOBM) production.

#### 3.1 Plants costs

A vast literature review has been performed to find the cost functions of the plants' equipment. Each equipment cost (EC) function is expressed as:

$$EC = BC \left( \frac{ES}{BS} \right)^\alpha \quad (2)$$

where BC is the base cost, BS is the base scale (i.e the reference plant size) and ES is the equipment scale (i.e the installed plant size); moreover, a scale factor,  $\alpha$ , is taken into account. In tables 3 and 4 these parameters are listed for the B2M and BH2M, respectively.

**Table 3.** Cost Functions parameters for the B2M plant

Equipment	BC [k€]	BS	$\alpha$	Scale Unit	Ref.
Biogas upgrading	1700	1000	1	$\frac{m^3}{h} \text{ biogas}$	[7]
Boiler	52	355	0.8	kWth	[8]

The operating costs are considered equal to the 4% of the initial investment cost for consumables. For the B2M plant the O&M costs are the 5% of the initial investment [7], while for the BH2M plant they are the 3% of the initial investment [12]. The replacement costs concern the catalysts and the stacks of the electrolysis unit. These costs are added in the CAPEX and are accounted every 40000 operating hours.

**Table 4.** Cost Functions parameters for the BH2M plant

Equipment	BC [k€]	BS	$\alpha$	Scale Unit	Ref.
PEM Electrolyzer	1345	1000	0.84	kWe	[9,10,11]
Stack Replacement	521	1000	0.925	kWe	[12]
H2 Storage	375	1000	1	$kg^{H_2}$	[13]
Methanation Reactor	2921	175	1	$MWh_{HHV}^{BM}$	[8,14]
Catalyst fill	563	175	1	$MWh_{HHV}^{BM}$	[8]

#### 3.2 Levelized cost of biomethane

The levelized cost of biomethane, LCOBM, is calculated referring to the plant lifetime as in equation 3, by taking into account the parameters in table 5.

$$LCOBM = \frac{\text{Total Costs (€)}}{\text{BM Production (kg)}} \quad (3)$$

With referring to the electricity prices, it is worth noting that the European pan-EU average of wholesale baseload prices (referred to last semester 2019) is pretty aligned with a RES based levelized cost of production of a wind generator (45.3 €/MWh vs 47.3 €/MWh). Thus, by assuming a renewable energy share of 25%, the weighted cost of electricity is equal to 45.8 €/MWh. The plant total cost, TC, has been calculated as in eq. 4.

$$TC = \sum_e EC_e + \sum_k \frac{RC}{(1+i_{eff})^k} + \sum_n \frac{VC+O\&M_e+CC}{(1+i_{eff})^n} \quad (4)$$

In the right term of the above equation, the first term is the sum of the Equipment Cost, EC calculated for each  $e^{\text{th}}$  equipment; RC, is the actualized Replacement Cost calculated in the k-years in which the replacement occurs. The last terms represent the actualized yearly expenses: VC, the Variable Cost is the sum of the expenses for biogas, electricity and water, O&M is the Operation and Maintenance cost and CC are the consumable cost. The effective interest rate,  $i_{eff}$  is calculated over the plants lifetime as function of nominal discount rate (i) and inflation (f):

$$i_{eff} = (1+i)/(1+f) - 1 \quad (5)$$

**Table 5.** Main assumptions for the economic analysis

Parameter	value	Ref.
Lifetime (years)	20	[3]
Discount rate, i (%)	5%	[7]
Inflation, f (%)	1%	[7]
Operating Hours (h)	8000	[3]
Grid Electr. Cost (€/MWh)	45.3	[15]
Wind LCOE (€/MWh)	47.3	[16]
Biogas Cost (€/m <sup>3</sup> )	0.05-0.15-0.35	[1] [3]
Water Cost (€/m <sup>3</sup> )	0.85	[17]

The biogas cost is assumed equal to 0.05 €/m<sup>3</sup> in the case of an existing digester and using of local biomass or waste, this cost is only based on the O&M costs; 0.15 €/m<sup>3</sup> adding the cost of the raw material and 0.35 €/m<sup>3</sup> in case the feed in tariff is further accounted [3]). Figure 4 shows the breakdown of the levelized cost of the biomethane for the two plant configurations and for the three biogas costs previously defined.

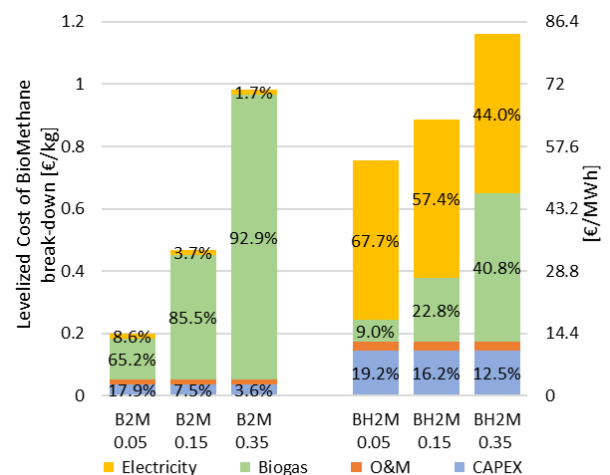

**Fig. 4.** LCOBM for the proposed plants at different biogas costs (0.05-0.15-0.35 €/m<sup>3</sup>)

The initial total investment cost results equal to 0.8 M€ for the B2M plant, whereas it is equal to 4.6 M€ for the BH2M plant. These very different values are due to the PEMEL unit that covers the 95% of the total investment costs in the BH2M solution. The capital cost adopted in the analysis refers to an estimation of the present costs, that are subject to reduction in the following decades [10]. For

such reason the CAPEX of the PEMEL will be analyzed in the next paragraph.

By considering the above defined weighted cost of electricity (45.8 €/MWh), the LCOBM for the BH2M system, is always higher than that of the B2M system, despite the highest biomethane production (369.5 kg/h vs 216.3 kg/h) because of the impact of the electricity consumption, accounting for the 57.4% of the production cost, and the greater installation costs (i.e. 16.2% vs 7.8% for the biogas cost of 0.15 €/m<sup>3</sup>).

### 3.3 Sensitivity Analysis

In order to evaluate the impacts of the main cost items on the LCOBM, a sensitivity analysis has been carried out. In figure 5, the results of this analysis are illustrated. The considered parameters are the biogas cost, the electricity price, the plant size and the operative hours. The effect of the water cost for the BH2M plant was not represented because it is below the 0.03%, while the PEMEL CAPEX was added since its price it is expected to decrease thanks to the increase of the market share and of the production volumes.

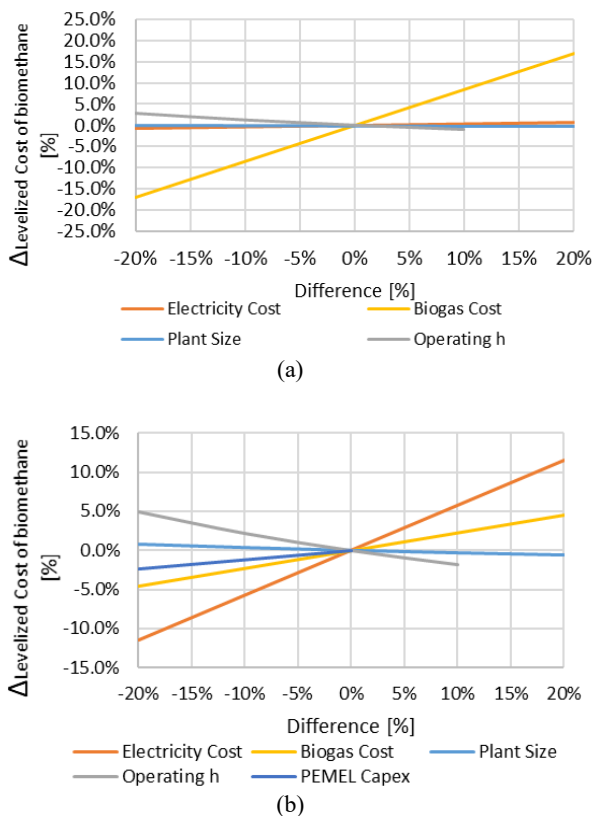

**Fig. 5.** Levelized cost of biomethane: Sensitivity Analysis for a) B2M hot potassium upgrading system, b) BH2M hydrogen to methane plant via direct methanation.

The reference point of the analysis was calculated with respect to table 5 input, selecting a biogas cost equal to 0.15 €/m<sup>3</sup>; the initial LCOBM is equal to 0.47 €/kg and 0.89 €/kg respectively for the upgrade-based and the PtG system. Figure 5 highlights as the biogas is the main contributor of the specific production price of the biomethane through upgrading, leading to an increase of the +16.7% of the LCOBM against a 20% of biogas cost

increase. As comparison, the second effect, related to the operating hours present a non-linear trend spanning from +2.80% for 6400 operative hours to a -1.02% for 8760 operative hours. The third driver of biomethane production cost is the electricity cost, with an impact of just +0.74% for an increase of the 20% of this parameter. The plant size as effect of the boiler scale factor, lead to an almost negligible decrease of LCOBM (-0.02%) for an increase of 20% of the inlet biogas mass flow rate. Looking at the BH2M results, the main driver of LCOBM variability is the electricity price, leading to an increase of the 11.5% of the LCOBM for an increase of the market price of the 20%. The second effect is related to the biogas input, with an impact of 4.56% for the same percentage variation. The effect of the operating hours (+4.90% for 6400 h and -3.26% 8760h) is higher than the one for the B2M plant because of the higher installation and replacement cost. It is interesting to notice that, even if not represented in the figure, by decreasing further the operating hours, a PEM Electrolyser replacement and a catalyst refill can be avoided, leading to a local minimum for 6000 operative hours for the LCOBM (+3.17%) equal to 0.92 €/kg. The effect of the plant size (+20%) lead to a decrease of the -0.78% of the production cost. Finally, by reducing the PEMEL installation cost to 1076 €/kW the production cost decreases of -2.33%. It is important to underline that the size of the electrolysis unit, the most expensive component of the plant, should be chosen through an optimization sizing process that accounts for the plant operation time depending on the intermittent renewable source and on the storage capacity.

### 3.4 Market Scenarios

Finally, also the effect of the increase of renewable share at grid level is analysed. In this regard, even if the RES LCOE is driven by the technology cost, the value of the kWh is related to the energy market. As matter of fact, an overproduction, due to an overgeneration of non-programmable RESs, or a decrease in the demand could reduce the price of electricity to values below the production cost. Under this condition, in countries as Germany and Austria, the price can find its balancing condition also with negative values, leading to misproduction of RES generators (i.e. curtailment). This will be the driver of future PtG systems that could act as responsive load to take advantage of that condition. According to this scenario, a preliminary analysis has been done considering the average electricity grid price.

Fig 6 allows to compare the production cost of biomethane under different electricity price scenarios. As expected, if the biogas cost is 0.05 €/m<sup>3</sup> the LCOBM of the simplest biogas upgrading plant is always lower than the PtG solution if negative grid prices are not considered. For the intermediate and maximum biogas cost, biomethane from PtG becomes competitive for electricity price respectively below 7 €/MWh and 30 €/MWh, making this solution suitable for a grid with high presence of renewable sources, acting as a responsive load to balance the overproduction peaks.

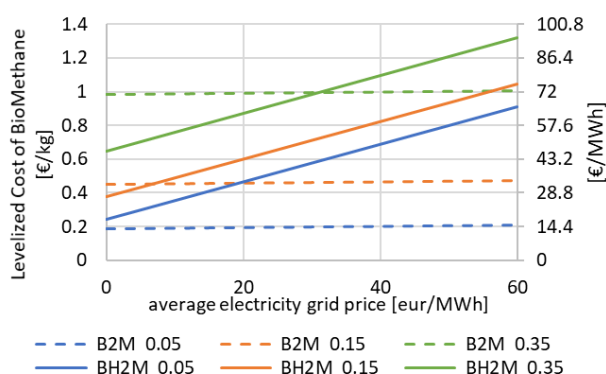

**Fig. 6.** Levelized cost of biomethane as function of the average grid electricity price; parameter biogas cost (0.05-0.15-0.35 €/m<sup>3</sup>)

## 4 Conclusion

This paper analysed two strategies to produce biomethane starting from biogas: the biogas upgrading by means of the chemical absorption with Hot Potassium Carbonate and the direct methanation of biogas by adding renewable hydrogen, as in a Power to Gas configuration. The methanation of the CO<sub>2</sub> allows to increase the biomethane production of about 71%, but the high electric consumption due to the PEM electrolyser results in lower efficiency (68%). The biogas upgrading plant, even if requires an additional biogas stream to produce the heat for the CO<sub>2</sub> stripping, has a higher conversion efficiency (87%).

On the economic side, the initial total investment cost for plants processing 500 Nm<sup>3</sup>/h of biogas, results equal to 0.8 M€ for the upgrading plant, whereas it is equal to 4.6 M€ for the Power-to-Gas plant, with the PEM electrolyser accounting for the 95% of the total installation cost of the latter. Looking at the levelized cost of biomethane, the upgrading system has a production price of 0.47 €/kg against 0.89 €/kg for the Power-to-Gas option for an electricity price of 45.8 €/MWh. For this option, the electricity cost has major impact on the biomethane production cost (54.7% for the intermediate biogas cost of 0.15 €/m<sup>3</sup>). For a biogas cost of 0.15 and 0.35 €/m<sup>3</sup>, the biomethane from the Power-to-Gas solution, become competitive for electricity price respectively below 7 €/MWh and 30 €/MWh, making this solution favoured in a grid with high presence of renewable sources, acting as a responsive load to balance the overproduction peaks.

## Nomenclature

B2M	Biogas to Methane
B2HM	Biogas and Hydrogen to Methane
BC	Base cost
BM	Biomethane
BS	Base scale
CAPEX	Capital Expenditure
CC	Consumable Cost
ES	Equipment Scale
EC	Equipment Cost
$i_{eff}$	Effective Interest Rate
LCOBM	Levelized Cost of Biomethane

LCOE	Levelized Cost of Electricity
O&M	Operational and Maintenance Costs
PEM	Proton Exchange Membrane
PEMEL	PEM Electrolyzer
PtG	Power to Gas
RC	Replacement Cost
RES	Renewable Energy Sources
TC	Total Plant Cost
VC	Variable Cost
$\alpha$	Scale factor

## Acknowledgment

The present research work has received funding from the Italian Ministry of Education, Universities and Research, MIUR, as Project of National Interest, PRIN 2017F4S2L3, HERMES.

## References

1. Minutillo M, Perna A, Sorce A, Combined Hydrogen, Heat and Electricity Generation via Biogas Reforming: Energy and Economic Assessments, *Int J of Hydrogen Energy* 44 (2019) 23880-23898
2. Minutillo, M., Perna, A., Sorce, A., Green hydrogen production plants via biogas steam and autothermal reforming processes: energy and exergy analyses, *Applied Energy*, 277 (2020) art. no. 115452,
3. Collet P, Flottes E, Favre A, L Raynal L, Pierre H, Capela S, Peregrina C, Techno-economic and Life Cycle Assessment of methane production via biogas upgrading and power to gas technology, *Applied Energy* 192 (2017) 282-295
4. Barbera E, Menegon D, Banzato D, , D'Alpaos C, Bertucco, A, Alberto. From biogas to biomethane: A process simulation-based techno-economic comparison of different upgrading technologies in the Italian context, *Renewable Energy*, 135(C) (2019) 663-673.
5. European Commission. Horizon 2020-Programme Fuel Cells And Hydrogen Joint Undertaking (Fch 2 Ju) Topic H2020-Jti-Fch-2015-1. Improved electrolysis for Distributed Hydrogen Production. Ga No. 700008
6. Peters R, Baltruweit Grube MT, Samsun RC, Stolten D, *Journal of CO<sub>2</sub> Utilization* 34 (2019) 616–634.
7. Paolini V, Torre M, Giacomini W, Pastori M, Segreto M, Tomassetti L, Carnevale M, Gallucci F, Petracchini F, Guerriero E, CO<sub>2</sub>/CH<sub>4</sub> separation by hot potassium carbonate absorption for biogas upgrading, *International Journal of Greenhouse Gas Control*, 83, (2019), 186-194
8. K. M. Holmgren, Investment cost estimates for gasification-based biofuel production systems (2015) Report B2221
9. Robinius M, Raje T, Nykamp S, Rott T, Müller M, Grube T, Katzenbach B, Küppers S, Stolten D, Power-to-Gas: Electrolyzers as an alternative to network expansion – An example from a distribution

- system operator, *Applied Energy* 210 (2018) 182-197
10. Gorre J, Ortloff F, Leeuwen C, Production costs for synthetic methane in 2030 and 2050 of an optimized Power-to-Gas plant with intermediate hydrogen storage, *Applied Energy* 253 (2019) 113594
  11. Bellotti D, Sorce A, Rivarolo M, Magistri L, Techno-economic analysis for the integration of a power to fuel system with a CCS coal power plant, *Journal of CO2 Utilization* 33 (2019) 262-272
  12. FCH-JU, Early business cases for H2 in energy storage and more broadly power to H2 applications (2017)
  13. Gorre J, Ruoss F, Karjunen H, Schaffert J, Tynjälä T, Cost benefits of optimizing hydrogen storage and methanation capacities for Power-to-Gas plants in dynamic operation, *Applied Energy*, Volume 257, (2020) 113967
  14. Bellotti D., Rivarolo M., Magistri L., Massardo A.F., Thermo-economic comparison of hydrogen and hydro-methane produced from hydroelectric energy for land transportation. *International Journal of Hydrogen Energy*, 40 (2015) 2433-2444
  15. Market Observatory for Energy, Quarterly report on European Electricity Markets, DG Energy, 12 (fourth quarter of 2019)
  16. IRENA (2020), Renewable Power Generation Costs in 2019, International Renewable Energy Agency, Abu Dhabi
  17. Salomone F, Giglio E, Ferrero D, Santarelli M, Pirone R, Bensaid S, Techno-economic modelling of a Power-to-Gas system based on SOEC electrolysis and CO2 methanation in a RES-based electric grid, *Chemical Engineering Journal* 377 (2019) 120233