

Rural road ecological landscape planning system based on interactive genetic algorithm

Chunlan Shen¹

¹Shanghai Lida University, Shanghai, 201609, China

Abstract: Traditional vegetation landscape spatial hierarchical planning system is faced with huge and complex real data, because its throughput is too low to get more accurate data, this paper proposes a rural road ecological landscape planning system based on interactive genetic algorithm. In the hardware design of the system, the structure distribution of ZingRDK feature extraction hardware is mainly designed, and the functions and parameters of the chip and HDMI interface in the structure are designed in detail. In the software design of the system, the interactive genetic algorithm is applied to the planning process, and then the visual feature reconstruction method is used to collect the green plant landscape image. The edge contour feature of the collected image is extracted, and the color component fusion method is used to enhance the information of green plant landscape image. The intuitionistic ambiguity set of multi-resolution landscape image is given, and the intelligent landscape planning result is calculated by fuzzy information clustering method. The results of the system test show that the net data throughput of the designed rural road landscape planning system is greater than that of the traditional planning system, which indicates that the plant landscape planning system has stronger ability to acquire and process data.

1 Introduction

The study of ecological green landscape intelligent planning and design method can play a more direct and effective role in improving the rural living environment. At present, the intelligent planning of rural road ecological landscape is based on the intelligent visual information processing technology. Combined with image processing technology, the intelligent planning system of ecological green plant landscape in rural residential environment is designed. The most basic and significant feature of rural road ecological landscape planning is to highlight people-oriented, and its road landscape planning concept is also very different. Therefore, exploring the new concept breakthrough of rural road ecological landscape planning and construction has become a problem that needs to be considered in rural road ecological landscape planning system.

In the traditional rural road ecological landscape planning system, the method and technology of rural road ecological landscape planning are analyzed, and the image classification of rural road ecological landscape in smart city is carried out by using visual image information processing technology. According to the classification results, the ecological landscape of rural road is artificially planned. This method consumes a lot of manpower and lacks intelligence. By using the linear programming design method, combined with the

artificial planning scheme, the ecological flexible boundary landscape of rural road is planned and designed, but the throughput of the artificial intelligence system for ecological green plant landscape planning is low. [1-2]. Due to the different complexity of the terrain and the different architectural patterns around, the calculation data are relatively complex, and the variability of plants and other natural conditions also make the data collection and processing very difficult. Therefore, the traditional vegetation landscape spatial hierarchical planning system can not get more accurate data because of its low throughput. This paper proposes a rural road ecological landscape planning system based on interactive genetic algorithm, which is different from the traditional rural road planning. Its road landscape planning concept is also different from the traditional rural road landscape planning concept. Interactive genetic algorithm is applied to the image processing and retrieval.

2 Rural road ecological landscape planning system based on interactive genetic algorithm

2.1 Hardware design

In the design of rural road ecological landscape planning system based on interactive genetic algorithm, ZingRDK is mainly selected as the feature extraction hardware of rural road. The SoC component integrated with processor

2080235@tongji.edu.cn

hard core and programmable logic can design ARM and FPGA simultaneously in feature extraction, which is more flexible. The embedded cross compiling technology is used to load and read and write the app control instructions of the rural road ecological landscape intelligent planning system. DSP is used as the information processor to develop the hardware of rural road ecological landscape intelligent planning system. In the application service layer, the remote control of rural road ecological landscape intelligent planning is realized, and the integrated information processor of rural road ecological landscape intelligent planning system is constructed. Human computer interaction design of rural road ecological landscape intelligent planning system in embedded control platform [3-4].

The MCU selected in the hardware adopts dual 12 bit A/D band sampling and holding internal reference source, and has dual 12 bit A/D synchronous conversion capability. It controls different working modes of the system hardware through SPI interface, and uploads and saves the buffered data [5]. According to the data acquisition instructions issued by the single chip microcomputer, the instrument collects the whole

building structure, vegetation coverage, path and other related data of the vegetation landscape site through the data acquisition module. The collector in the system collects the data of the whole area, length, width, height, ground slope and other building volumes of the planning space, and then collects the data of plants. The selected sensor model is MILT-MPSS1000A2. The collected data is uploaded to the central processing unit of the system to process the real-time data. The hardware of the data acquisition and transmission system is used as the basis of the design of the hierarchical system of plant landscape space to provide hardware support for the proposed system.

2.1.1 Chip design

ZingRDK feature extraction kit uses XC7Z020-1CLG484C Zynq-7000 EPP chip, which can integrate processor hard core and programmable logic SoC components. The overall block diagram of the chip is shown in Figure 1.

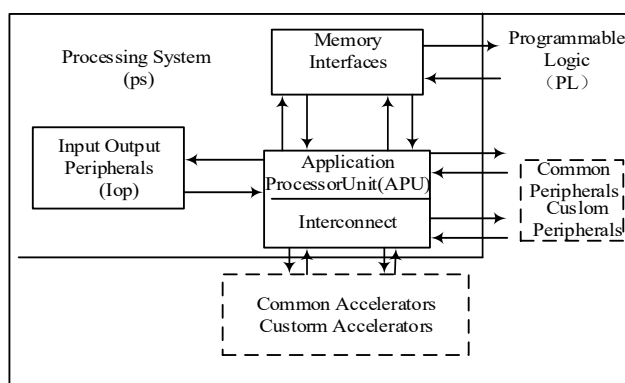

Figure 1 Overall block diagram of the chip

Among the selected chips, the processor hardware core is the application level processor of ARM A-08, which can carry SoC components and run successfully. The chip is based on the same architecture, the main difference between different models of chips is that the integrated hardware core of the processor has different resources. The connection between processor hard core and SoC component of programmable logic is industrial standard advanced extensible interface (AXI), which realizes high bandwidth and low delay data interaction in these two parts.

2.1.2 Design of HDMI interface

HDMI full name is high definition multimedia interface. It is a digital video / audio interface. ZingRDK is used as feature extraction hardware in the system, with HDMI interface. The chip dominates the signal transmission, and daily data interaction is mainly completed through HDMI interface. It is mainly composed of source and sink, which can meet the 1080P resolution video playback, a variety of audio formats are compatible, and the maximum transmission speed can reach 10Gbps, which can meet the standard requirements of HD era. In

the process of HDMI port and connector, the HDMI port should be connected with DTA platform first. After setting, the HDMI connector (JH 1) pin can access the data memory at high speed, and set the baud rate to 1231000 when setting the baud rate. So far, the hardware design of rural road ecological landscape planning system based on interactive genetic algorithm is completed.

2.2 Software design

The basic principle of interactive genetic algorithm is as follows. Firstly, the algorithm initializes a population randomly and presents the phenotypes of all individuals in the population to users. Then, users are compared with different individuals, current individuals, and ideal individuals. According to the individual's feeling, the evolutionary individual is given fitness value, and the human and algorithm cooperate to complete the evolution process of the population. Finally, the user satisfied individuals are found in the feasible region of the problem to be optimized. The flow chart is shown in Figure 2.

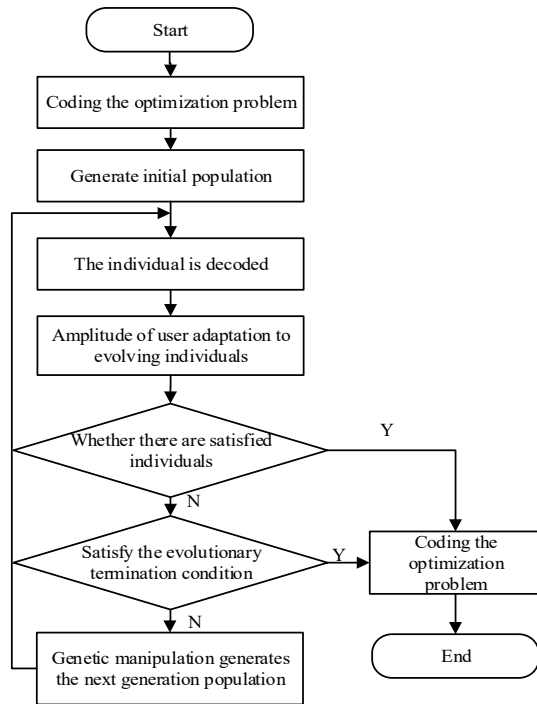

Figure 2 Flow chart of interactive genetic algorithm

In order to realize the intelligent planning and design of ecological green plant landscape in rural residential environment, the visual information collection model of ecological green plant landscape was established by combining with computer vision image processing method. Firstly, the image of ecological green plant landscape in rural residential environment is collected and processed to improve the feature resolution of ecological green plant landscape in rural residential environment. The multi image loading method was used to sample the landscape image of ecological green plants in rural residential environment. Interactive genetic algorithm is used to match the image template of ecological green landscape. Using template registration method, the ecological green plant landscape in rural residential environment to be planned is divided into 3×3 topological structure, and four planning templates of ecological green plant landscape in rural residential environment are set up. The fusion feature quantity of ecological green plant landscape in rural residential environment is $\eta(x, y)$. In the connected area of ecological green plant landscape planning, the gray scale pixel $f(x, y)$ of image sampling is obtained as shown in formula (1):

$$f(x, y) = \begin{cases} g(x, y) - H, & \text{if } g(x, y) - f_{Lee}(x, y) \geq t \\ g(x, y) + H, & \text{if } g(x, y) - f_{Lee}(x, y) < t \\ g(x, y), & \text{else} \end{cases} \quad (1)$$

In formula (1), $g(x, y)$ represents the road landscape coordinates of the collection area. In this paper, a multi-resolution landscape planning method of ecological green plants in rural road environment is used to construct affine invariant region of feature matching in the central pixel. According to the spatial distribution attribute of ecological green plant landscape in rural road environment, the wavelet scale information entropy is

H . When the more information of H , the higher the similarity intensity of ecological green landscape in rural road environment, the closer $f(x, y)$ will be to $g(x, y)$. In the domain of genetic algorithm, the ecological green plant landscape in each sub-band of rural road environment is binarized, and the joint distribution coefficient of color and texture of ecological green plant landscape in rural road environment is obtained. According to the similarity of the contents of the two ecological green landscape in the rural residential environment, the multi feature fusion method is used to extract the regional characteristics of the ecological green landscape image, which is the additive noise term of the ecological green landscape in each sub belt rural residential environment. In the case of only additive noise, the fuzzy adaptive feature component method of ecological green landscape image is decomposed. The interactive genetic algorithm is used to carry out the adaptive weighting of ecological green landscape, extract statistical characteristics, and realize the high-resolution recognition of ecological green landscape in rural residential environment. So far, the design and research of the system have been completed.

3 Experiment

3.1 Experimental environment

The simulation experiment platform is built, in which there are two computers with the same model and configuration. The simulation experiment environment parameters are shown in Table 1.

Table 1 Simulation test environment

Serial number	Name	Parameter
1	Operating system	Windnw 2018
2	System memory /GB	128
3	CPU	Intel, Core i5-24110m, memory 8 GB
4	CPU main frequency /MHz	330
5	Application server	Ggda-25T5 dedicated server
6	Server database	Oracle 11g
7	Simulation experiment software	Matlab R2018b
8	Test tool	TCP tool
9	Information storage /GB	256
10	Working frequency /MHz	420

The designed planning system and traditional planning system are respectively loaded into the electronic computer of the experimental platform and initialized. The data acquisition end in the system test is

connected with the LAN end of router. The IP address of the system hardware is 192.168.1.200 and the designated port is 4619. Ping sends out an Internet message control protocol to send messages to the destination via echo requests and tells if the desired ICMP response is received. The results of the response are shown in Figure 3.

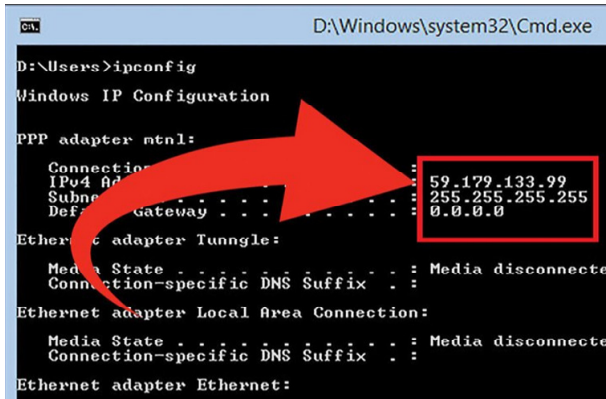

Figure 3 Computer connection response results

According to Figure 3, it can be seen that the test system of the simulation experiment electronic computer replies to the Ping instruction four times under the instruction of Ping 59.179.133.99 four times in succession. The test results show that the network connection between the two is stable and normal. Because this test is completed by TCP tool, after the above connection is established, the data acquisition module of the two plant landscape planning systems in the computer will send the data to the server master station of the computer. After the connection is completed, the connect OK word can be printed in the receiving area, and all the software and hardware are connected. In the simulation experiment, the landscape planning designed by the method of this paper and the traditional method designed were tested. The parameters and results of the test were analyzed and compared.

3.2 Analysis of test results

Two kinds of rural road ecological landscape planning systems are used for rural road ecological landscape planning, and the collected rural road ecological landscape data is uploaded to the central processing module through their transmission module. At this time, the hardware interface parameters of the system are shown in Table 2.

Table 2 Hardware interface parameters of data acquisition module

Parameter	The system designed in this paper	Traditional system
Transmission speed	<4.6Mb/s	<644.1Kb/s
Transmission mode	Split signal	Logic level
Driving power	<337	Point to point

According to Table 2, the designed rural road ecological landscape planning system improves the transmission speed to more than 2 Mb/s and extends the communication distance to 4900 ft through the redefined communication interface. It can be seen that the design of the planning system increases the multi-point two-way communication capacity, expands the data processing capacity of the system, and obtains the comparison results as shown in Figure 4.

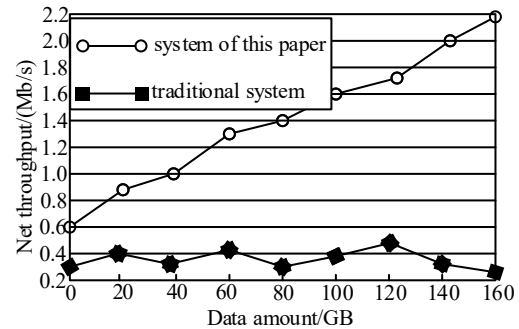

Figure 4 Comparison results of planning system throughput

It can be seen from Figure 4 that under the premise of planning and designing 160GB of data information, the net data throughput of the planning system increases steadily with the increase of rural road ecological landscape data information. It shows that the design of the planning system can quickly analyze and process the huge amount of data and complex types of plant landscape data, so as to achieve the spatial hierarchical planning and design of landscape. However, the net data throughput of the traditional planning system does not increase with the increase of data volume, which indicates that the traditional planning system can not process the huge landscape data.

4 Conclusion

This paper proposes a rural road ecological landscape planning system based on interactive genetic algorithm. In the hardware design of the system, the structure distribution of ZingRDK feature extraction hardware is mainly designed, and the functions and parameters of the chip and HDMI interface in the structure are designed in detail. In the software design of the system, the interactive genetic algorithm is applied to the planning process. Fuzzy information clustering method is used to calculate the result of landscape intelligent planning. The results of the system test show that the net data throughput of the designed rural road landscape planning system is greater than that of the traditional planning system, which indicates that the plant landscape planning system has stronger ability to acquire and process data. But also speeds up the landscape design speed. At present, it only solves the problem of huge amount of information of landscape data. In the future research, it is necessary to improve its ability of spatial level automatic planning.

Acknowledgments

The study was supported by “Shanghai Education Research Project, China (Grant No.C2-2020021)”.

References

1. Moreto R. , Thomaz C. E. , Gimenez S. P. (2019) Impact of designer knowledge in the interactive evolutionary optimisation of analogue CMOS ICs by using iMTGSPICE[J]. *Electronics Letters*, 55(3):16-18.
2. R.A.L. Moreto, C.E. Thomaz,S.P. Gimenez. (2019) Impact of designer knowledge in the interactive evolutionary optimisation of analogue CMOS ICs by using iMTGSPICE[J]. *Electronics Letters*, 55(1):16-18.
3. Feroz S. , Varghese M. , Dutta S. . (2020) Solar Nano-photocatalytic Pretreatment of Seawater: Process Optimization and Performance Evaluation using Response Surface Methodology and Genetic Algorithm[J]. *Applied Water Science*, 11(2).
4. Carrillo F., Roner S., von Atzigen M., et al. (2020) An automatic genetic algorithm framework for the optimization of three-dimensional surgical plans of forearm corrective osteotomies.[J]. *Medical image analysis*, 60: 101598-101598.
5. Ahn G. , Park M. , Park Y J. , et al. (2019) Interactive Q-Learning Approach for Pick-and-Place Optimization of the Die Attach Process in the Semiconductor Industry[J]. *Mathematical Problems in Engineering*, 2019(PT.4):1-8.