

A Coal Mine Safety from Conventional to Modern Method Through LoRaWAN

B. Vandana^{1,*}, Rongali Varalakshmi², Kalyani Malik³, and Lyagala Abhishek⁴, Mamatha Samson⁵ and Gaurav Singh Negi⁶

^{1, 2, 3, 4}Department of Electronics and Communication Engineering, KG Reddy College of Engineering & Technology, Hyderabad, India,

⁵Professor, Department of Electronics and Communication Engineering, GRIET, Bachupally, Hyderabad, Telangana

⁶Uttaranchal Institute of Technology, Uttaranchal University, Dehradun, 248007

¹vandana.rao20@gmail.com, ²rungalivaralakshmi9@gmail.com, ³kalyani.m0909@gmail.com,

⁴abhimudhiraj6900@gmail.com, ⁵mamata2001@gmail.com, ⁶gauravneg@uumail.in

Abstract. In this paper, a data transmission method called Thing Speak is used to construct a coal mine safety system. The system is used to monitor and regulate a number of characteristics in coal mines, including light detection, gas leak detection, temperature and humidity conditions, and coal mine fire detection. These sensors are all installed in coal mines and are regarded as a single unit. For analysis, all sensor values are continuously uploaded to Thingspeak and buzzer is utilized to notify the staff. The created technology is primarily used to enhance worker safety and the working environment in coal mines.

Keywords— Fire, Gas, water, Temperature, Internet of things, LoRa Technology, Thing speak

1 Introduction

Coal mining is a dangerous job that requires employees to operate in challenging settings where they are exposed to a variety of risks and hazards. These dangers include the possibility of roof collapses, gas leaks, explosions, and other mishaps that could lead to critical injury or fatality. Thus, protecting coal workers' safety is of utmost importance in the mining sector.

Implementing policies and practices to minimize mishaps, lower hazards, and safeguard employee health and welfare is part of maintaining safety in coal mines. These precautions entail the use of safety gear like safety harnesses, respirators, and helmets as well as the execution of safety procedures including routine inspections, training sessions, and emergency response plans. equipment to increase coal mine safety. These comprise real-time gas level monitoring systems, personnel and equipment tracking systems, and emergency communication tools. equipment to increase coal mine safety. These comprise

real-time gas level monitoring systems, personnel and equipment tracking systems, and emergency communication tools.

Mining is the practice of digging coal out of the ground. Natural conditions in coal mines are incredibly complicated, and mining conditions are frequently unpredictable. The design of a coal mine is complex; there is little capacity for branch tunnels and they can go in any direction. The main tunnel is typically the only place where wired transmission systems may be installed, which significantly limits the network's capacity to expand. It is obviously impossible to continuously monitor these dangerous locations while underground mining is taking place because a connected network cannot be created in real time. Due to financial and maintenance constraints, abandoned underground tunnels also lack safety monitoring equipment, which poses a serious threat to public safety. [1, 2].

1.1 Conventional Methods

In Coal mining has long employed conventional techniques, but recent technical developments have resulted in the creation of fresh, more effective techniques. While more modern methods have supplanted some of the traditional ones employed in coal mining, others have been improved with technology. Here are a few instances:

Mining in pillars and rooms: This technique has been around for a while and is still popular today. However, technological advancements have improved its effectiveness and safety. For instance, the extraction of coal can be done with automated machinery, which eliminates the need for human labour in hazardous locations.

Longwall mining: Has also benefited from technological advancements, such as the use of cutting-edge sensors to track the movement of the roof. And the seam of coal. This could increase effectiveness and help avoid mishaps.

Surface mining: With the use of cutting-edge machinery like draglines, which can swiftly and effectively remove significant amounts of overburden, this method has been substantially enhanced. Additionally, mining equipment is guided by GPS technology to assure proper coal seam extraction [3].

Since there are so many potential catastrophes in mines, establishing safety is quite challenging. Because of this, coal mining is less secure and serious accidents are more likely. Regarding the monitoring of coal mine safety, there are still many problems with wired monitoring and control that need to be resolved. Wired coal mine safety monitoring and control systems are challenging to implement in many coal mine environments, such as abandoned tunnels and mining sections. The safety and health monitoring system for coal mines is the focus of our project. The coal mine's sensors can detect every hazardous gas using gas sensors, temperature sensors, and humidity sensors. The buzzer will turn on when the fuel exceeds the threshold level.[4]

This Coal is a preferred raw resource for numerous industries. It is used to create electricity in addition to extracting a variety of by-product chemicals and minerals. But extracting coal from a coal mine is a difficult and dangerous task. Numerous coal mine accidents around the world result in fatalities and financial loss. Risks and hazards can be considerably reduced by modern smart technology. Right now, miner safety is a top priority. The health and lives of miners are in danger due to a number of important factors, including the working environment and its repercussions. A new strategy is needed to improve mining productivity, save costs, and preserve worker safety [4].

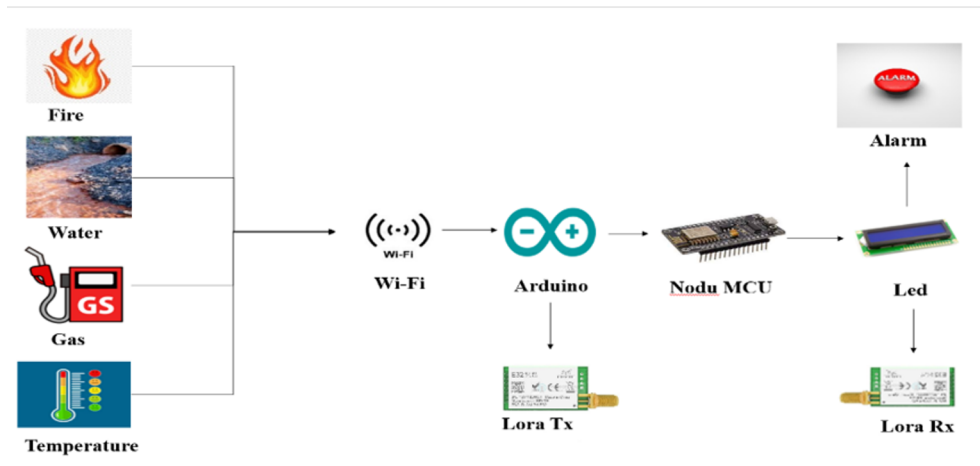

Fig. 1. Coal Mine using Lora WAN Architecture.

2 Related Work

2.1 IOT Based Smart Mine Safety System Using Arduino

Recent coal mine safety incidents have led to several fatalities and substantial monetary losses. "IOT-based ZigBee-based coal mine safety monitoring and control automation" (IEEE). The worldwide mining industry must increase operational efficiency and all-around mining safety. In order to automate the remote monitoring and control of physical sensor devices buried below, this research recommends a simple mashup middleware. A universal devices access architecture based on the Open Service Gateway initiative (OSGi) is first presented, and a cluster tree based on the ZigBee Wireless Sensor Network (WSN) is constructed underground in a coal mine. A graphical user interface for various subsurface physical sensor devices might be created with the help of visualization technologies, allowing the sensors to readily integrate with other resources [1].

2.2 IOT Based Coal Mine Safety Monitoring and Alerting System

According to the paper a Methodology for Understanding and Improving Coal Mine Safety by Investigating Coal Mine Risk Network, coal mining is one of the riskiest industries in the world. Accidents can commonly occur during the coal mining process due to a variety of dangers, including rock stresses, dangerous gases, moisture, high temperatures, coal and silica dust, and severity of these risks may have a highly detrimental impact on people's lives and health [2].

2.3 IoT Based Coal Mine Safety Monitoring and Controlling

Accidents in coal mines greatly raise the danger of harm, death, and the destruction of vital corporate assets. The article, titled Effect of Gas Control Policy on the Gas Accidents in Coal Mine, Coal has contributed significantly to the world's energy supply during the last few centuries through generating heat, electricity, and other essential industrial products.

Today, roughly 27.7% of the primary energy used in the globe still comes from coal. According to statistics, coal consumed worldwide in 2018 amounted to 3.772 billion tonnes of oil equivalent. China now consumes the most coal and emits the most carbon dioxide related to energy globally. (CO₂). Around 80% of China's annual energy-related emissions are caused by burning coal and products made of coal [3]

2.4 Coal Mine Safety Monitoring and Alerting System

This method has a flaw in that the hardware is prone to damage in the case of a natural disaster or a roof collapse because it is housed inside coal mines. As a result, traditional communication methods lack sufficient dependability and endurance. Installation and maintenance of the system are particularly challenging due to the dangerous environment inside the mine. Another issue is that because of the excessive noise inside coal mines, miners who are far from the system have a difficult time receiving the proper messages. This system uses a network of wireless sensors based on the Zigbee protocol to create an intelligent safety and monitoring system for underground coal mines. [4].

2.5 Underground Mines Wireless Propagation Modeling

In this article, the application of IoT technology in underground coal mines has demonstrated significant promise for improving productivity and safety. In this literature study, we will look at an Internet of Things (IoT)-based dynamic information platform for underground coal mine safety. An IoT-based dynamic information platform for underground coal mine safety was proposed in the paper that was published in the Journal of Mining Science and Technology. A central control unit was connected to a network of sensors, such as gas sensors, temperature sensors, and humidity sensors. The system was created to monitor the mining environment continually and identify dangers including gas leaks, fires, and collapses. A communication feature on the site allowed users to send and receive real-time smartphone alerts in the event of a danger. [5].

3 Methodology

This suggested system for the coal mine safety systems is fixed and includes gas sensor modules, temperature sensors, and fire sensors. Each sensor has an Arduino connected to it. We must first create a Thingspeak account. In this system, keeping track of all the data flowing from various sensors is mostly done by monitoring and regulating systems. In the coal mine environment, a gas sensor detects gas; if the level of gas exceeds the typical threshold, the buzzer activates to warn the mine staff. These sensor measurements are continuously sent to the cloud (Thingspeak.io) for analysis and future usage. Temperature and humidity are also gauged inside the coal mine.

3.1 LoRaWAN

A low-power vast area network (LP-WAN) called LoRa is explicitly created for the Internet of Things (IoT) and innovative sensor applications. As the name suggests, LoRa is a prominent player in IoT networks thanks to its ability to transmit vast distances using less power. A message from any device can be received by one or more gateways using LoRa technology. The central network will receive the communications and forward them for processing. The notifications will be handled by clever server architecture and sent to all relevant applications. The LoRa Alliance is a membership-based, open, non-profit organisation that develops, maintains, and enhances the LoRa standard. One of the main forces behind this incredibly effective LP-WAN technology is the Internet of Things [7].

The initial calculations can be used to determine the overall transmission time for a single LoRa packet by acquiring the values for the spreading factor (SF), coding rate (CR), and signal bandwidth (BW).

Fig. 2 describes the preceding calculations that can be used to determine the overall transmission time for a single LoRa packet by acquiring the values for the spreading factor (SF), coding rate (CR), and signal bandwidth (BW).

The typical approach for measuring the end-to-end time delay of network communication is to immediately transmit a probe packet to obtain the end-to-end delay value. The computation is too tricky if Equation (1) must be used to estimate the LoRa transmission latency. However, RTT is typically employed instead of an end-to-end time delay to assess performance. Equation (2) refers to the time between the moment data are delivered and the moment the sender receives a feedback packet from the receiver. The Equation (3) refers to the measuring programme that involves keeping track of the sending and receiving time points. The RTT is calculated by subtracting the transmitting time points from the receiving ones. receiving time points. The RTT is calculated by subtracting the transmitting time points from the receiving time points.

$$ToA = T_S * (T_{pre} + Max(\Lambda * (CR + r), 0)) \quad (1) [8]$$

$$\Lambda = 8PL - 4SF + 28 + 16CRC - \frac{20H}{4} * (SF - 2DE)(2) [8]$$

$$T_S = \frac{2sf}{BW}, T_{Pre} = (npre + 12.25) \quad (3) [8]$$

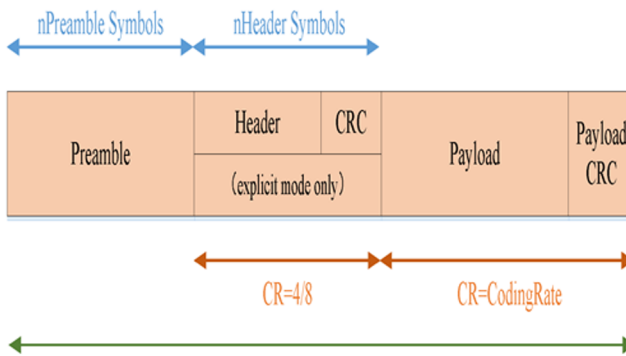

Fig. 2. Packet structure of LoRa [8]

3.2 Node MCU

The Node MCU development board and open-source firmware are created exclusively for Internet of Things (IoT) applications. Its hardware is based on the ESP-12 module, and its firmware is powered by ESP press if systems ESP8266 Wi-fi SoC. Using appropriate registers, the ESP8266EX's 17 GPIO pins can be configured for several functions. Data are saved in software registers when a GPIO is configured as an input. The input can also be configured to produce edge-trigger or level-trigger CPU interrupts. Each GPIO can be adjusted to high impedance, internal pull-up or pull-down, or both. The input and output buffers on the non-inverting, tristate, bidirectional IO pads have tristate control inputs [9].

3.3 DHT 11

The DHT11 humidity sensor. The second sensor in this series is the DHT. These two sensors measure the relative humidity (RH). As a result, DHT will measure both the humidity and temperature. Beginners and hobbyists favour DHT11 humidity sensors

despite their slowness and low cost. The following is a list of the three main components of the DHT11 humidity and temperature sensor. An 8-bit microprocessor, a resistive type humidity sensor, a negative temperature coefficient (NTC) thermistor (to monitor the temperature), and other parts convert the analogue outputs from the two sensors into a single digital signal and send them out. This digital signal can be read by any microprocessor or microcontroller and used for further analysis. The DHT11 is a sensor for humidity and temperature: VCC, data output [1].

3.4 Arduino UNO

The Arduino Uno is an open-source microcontroller board created by Arduino.cc and was first available in 2010. It is based upon the micro-chip ATmega328p microprocessor. Various expansion boards and other circuits can interface with the board set of digital and analogue input output (I/O) pins. The board features six analogue I/O pins, six digital I/O pins, and 14 digital I/O pins, six of which can be used for pulse width modulation (PWM) output. It can program using the Arduino IDE (Integrated Development Environment) with a type B USB connector. A barrel connector that can handle voltages between 7-20 volts, such as a square 9volts battery, or a USB (Universal Serial Bus) cable are both options for powering it [1].

3.5 Gas sensor

The Gas sensor responds quickly and with high sensitivity. A sensor in gas detectors measures the concentration of certain gases in the atmosphere. The sensor serves as a reference point and scale when a chemical reaction brought on by a specific gas takes place, producing a measurably large electric current [1].

3.6 Embedded C

It has embedded systems development as historically utilised high-level language programming. However, assembly programming is still popular, especially for digital signal processors (DSP) systems. DSPs are frequently designed in assembly language by developers who are experts in processor architecture. Performance is the primary driving force behind this technique, despite assembly programming's shortcomings compared to high-level language programming. The performance gap between the standard C and Embedded hardware and application architecture is intended to be filled by Embedded C. It adds primitives to the C language that are frequently offered by DSP processors and are required by applications for signal processing. Based on DSP-C, the design of Embedded C's support for named address spaces and fixed-point data types [1].

3.7 Fire Sensor

An alarm system or control panel receives a signal from a fire sensor when it senses the presence of fire or smoke. The sensor helps prevent significant damage and injuries in a closed area. These sensors are utilised in various contexts, including residential houses, commercial buildings, and industrial sites. Ionisation smoke detectors, photoelectric smoke detectors, heat detectors, and flame detectors are a few examples of the various kinds of fire sensors. While photoelectric smoke detectors employ a beam of light to detect smoke, ionisation smoke detectors detect the presence of smoke particles in the air. Heat detectors pick up temperature changes, whereas flame detectors pick up the presence of flames [10].

In Table1 describes WSN (wireless sensor network): Multiple sensors that connect wirelessly with one another to gather and transfer data make up a WSN [11].

3.8 Zigbee

Describes for low-power, low-data-rate applications, Zigbee is a wireless communication technology. It is frequently utilised in wireless sensor networks, industrial automation, and home automation systems [12].

IoT (Internet of Things): The Internet of things is a network of physical objectives such as applications such as cars, and householding things, equipped with sensors, software and hardware. It is used for network connectivity to collect and share data [13].

LoRaWAN (long-range Wide area network): Long-range, low-power applications are the focus of the LoRa (Long Range) wireless communication technology. It is frequently utilised in IoT applications for smart cities, industrial automation, and other areas.

Table 3. Technology Comparison table for existing and proposed work

Parameters	Existing Work			Proposed Work
	WSN	ZIGBEE	IOT	LoRa
Transmission speed	200Kbps	250Kbps	9600Kbps	0.3-50Kbps
Frequency range	315MHz	916MHz	490Hz	860MHz
Power supply	12v	12v	12v	12v
Distance	100m	50-1600m	40m	900m

4 RESULTS AND DISCUSSION

The Arduino microcontroller integrates the sensors and tests them for functionality. The mines are being evaluated and watched according to the criteria above for worker safety. When gas leaks, the voice playback mode lets you know that the gas is high.

The system implies that many monitoring systems are in place to ensure worker safety. Similar to how it shows the possibility of a landslide when vibration is significant in a specific area. When a high temperature is reached, a voice playback recorder is used to convey that the temperature in that area is also high. Finally, a multi-monitoring system that ensures the safety of mine workers in coal mines and prevents fatalities is being used.

A coal mine safety system uses fire, gas, LDR, and DHT11 sensor technology to provide safety measures to the worker. This device alerts the miner and continuously monitors the coalmine via Thing speak. The system is efficient and productive.

A. Implementation

In Fig. 3, depict the flow chat of coal mine safety working process. Initially sensors have been installed all over the mine to monitor temperature, humidity, and gas concentrations. Data from the sensors is collected by the LoRaWAN gateway and sent to the cloud. The cloud quickly examines the data and generates alarms if any sensors detect a dangerous situation or if there is any departure from safe operating settings. The notifications are sent to the mine control centre so that it can take action to ensure the safety of the personnel. The control centre can use the data to improve mine safety processes and run more effectively. The system can be regularly examined and adjusted to ensure peak performance and safety.

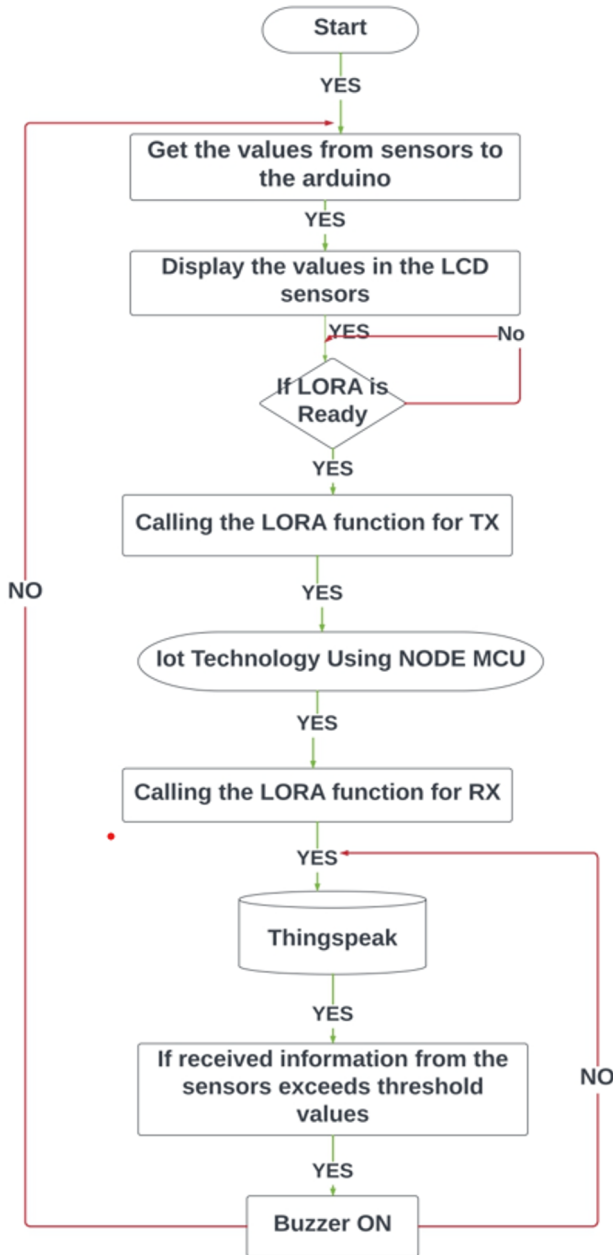

Fig. 3. Flowchart for the coal mines safety

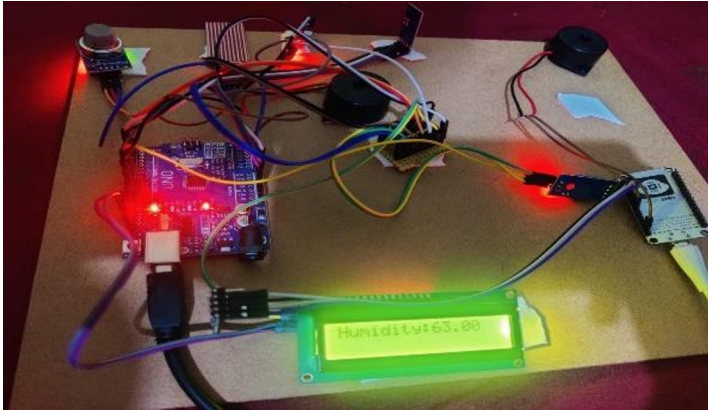

Fig. 4. Circuit diagram for Humidity

In Fig. 4 shows about the Humidity in the Hardware kit it represents the when workers working in cramped places, high humidity can make it uncomfortable for miners and make it more difficult for them to breathe. Fog or mist production due to high humidity can also limit visibility, making it more difficult for miners to see and avoid dangers. Then the sensor will detect the workers' humidity in the underground. Then the buzzer starts alerting.

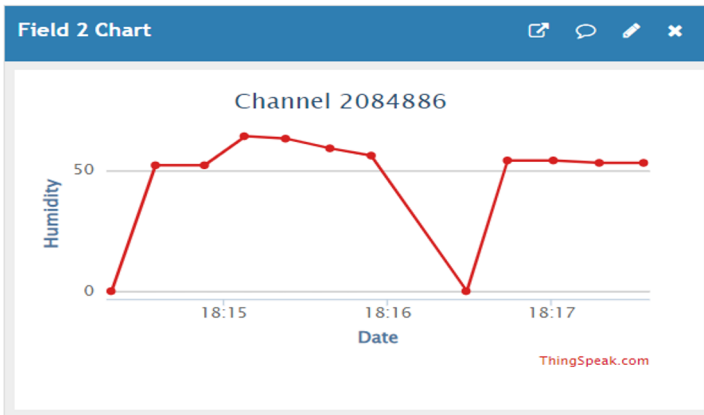

Fig. 5. Graphical representation of the Humidity

In Fig. 5 the graph shows the threshold is '50' when the humidity is increased the the buzzer will be on so the person on transmitter side and also receiver side they can know that they are in danger so they get out side immediately and also when the threshold value decreases the buzzer will be on with this also they can know that the humidity is decreasing so they will get out side about the workers are exists in the underground. It uploads in cloud and the data will shows in the thingspeak.

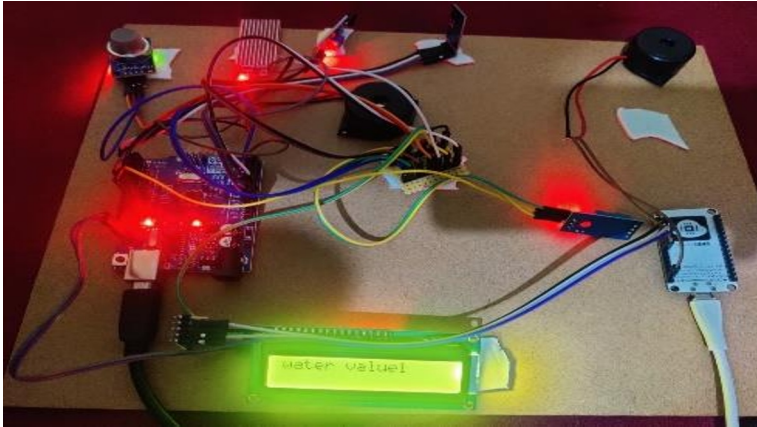

Fig. 6. Circuit Diagram for Water level Sensor

In Fig. 6 shows represent the water level sensor in the hardware kit it represents Natural sources like groundwater or intense rainfall can cause water to accumulate in coal mines and produce flooding, which can halt mining operations. Water can interact with specific chemicals and gases to create dangerous situations, increasing the risk of explosions in coal mines. Pumps and drainage systems are installed to remove extra water from coal mines to control water levels. Monitoring devices are also set up to track water levels and find any changes or peaks.

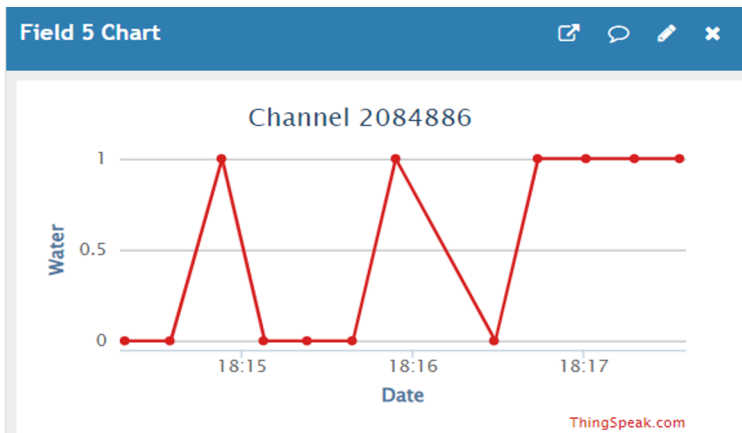

Fig. 7. Graphical representation of the water level

In Fig.7 the graphs represents about the water level of the coal mine while digging the coal mines the water is getting out with that the work will stopped and also when they get high getting chances of death of the person for this project threshold value is '1' given with that they will get idea and they will get out of the coal mine. An explosion brought on by a methane build-up may result in significant harm or even death.

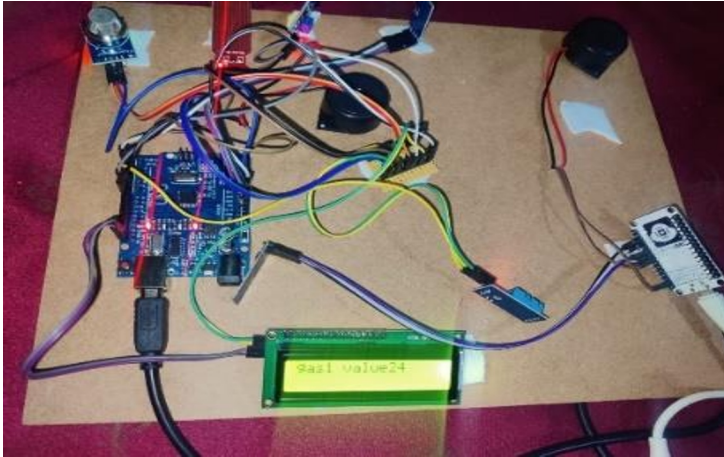

Fig. 8. Circuit diagram for gas sensor

In Fig. 8 depict the gas sensor in the hardware kit it represents the alert visualizing through an LCD display. Currently, the only head protection available to miners is helmets. This project aims to help the coal mines works that can transfer data to a base station through Zigbee and identify the presence of dangerous gases and coal mining risks. A semiconductor gas sensor is used to measure the levels of hazardous gases like SO₂, NO₂, CO, etc., in coal mines.

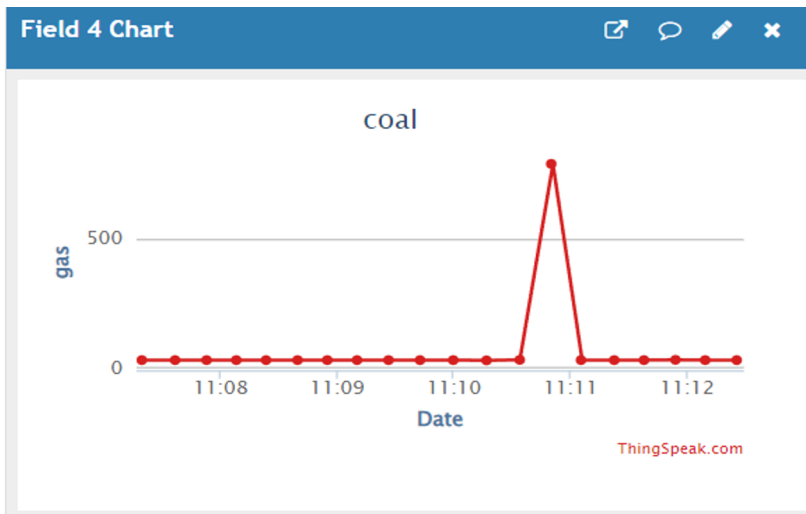

Fig. 9. Graphical Representation of the Gas

In Fig. 9 the graphs represents about Several gases with this gas explosion with this lungs may get damaged and person may die and get some skin diseases in this gases, including methane, carbon dioxide, and carbon monoxide, can be found in coal mines and can seriously danger the safety of miners. In the gases explosion threshold value is '500' have given above that value then the buzzer will get on then the sound will get with that person get out off that coal mine the most prevalent gas in coal mines is methane, the most explosive and flammable gas. about the plots are extracted to show how the workers exist underground. It uploads to the cloud, and the data will become visible.

	A	B	C	D	E	F	G
1	created_at	entry_id	Temperature	Humidity	Fire	Gas	Water
2	2023-04-12T18:14:19+05:30	1	0	0	0	0	0
3	2023-04-12T18:14:35+05:30	2	35	52	1	25	0
4	2023-04-12T18:14:53+05:30	3	35	52	1	25	1
5	2023-04-12T18:15:08+05:30	4	35	64	1	25	0
6	2023-04-12T18:15:23+05:30	5	35	63	1	25	0
7	2023-04-12T18:15:39+05:30	6	35	59	1	25	0
8	2023-04-12T18:15:54+05:30	7	35	56	1	23	1
9	2023-04-12T18:16:29+05:30	8	35	55	1	23	1
10	2023-04-12T18:16:44+05:30	9	35	54	1	27	1
11	2023-04-12T18:17:01+05:30	10	35	54	1	24	1
12	2023-04-12T18:17:18+05:30	11	35	53	1	24	1
13	2023-04-12T18:17:34+05:30	12	35	53	1	24	1

Fig. 10. The output Data is saved in Excel sheet

The data observed in the Excel sheet is uploaded to the cloud that will be shown in graphical representation through thing speak.

Accessibility: You may access your Excel sheet from any location with an internet connection by storing it in the cloud. Greater flexibility and teamwork are made possible by this.

Real-time updates make it simple to collaborate on the same document with others at the same time. Any changes made to the Excel sheet will be updated in real-time.

Security: Storing your Excel sheet in the cloud adds extra protection because most cloud service providers encrypt data and take other security precautions to keep it safe.

5 Conclusion

The project is implemented through embedded system technologies, and LoRa WAN, the coal mining safety and health monitoring system project, represents a significant development for the sector. In this project, data from IoT sensors is wirelessly transmitted to an embedded system using LoRa WAN technology. The embedded system evaluates the data and creates alerts for potential safety issues. By providing real-time monitoring of working conditions, the adoption of this project will aid in lowering the frequency of accidents, injuries, and fatalities in coal mines. Additionally, it will help in the early detection of health problems brought on by exposure to silica and dust, two harmful compounds found in coal mines

References

1. S. Sujitha, J. B. S. Loret, and M. Gethsy, "IOT based smart mine safety system using Arduino," *Int. J. Comput. Sci. Mob. Comput*, vol. 9, pp. 141–145, 2020.
2. A. H. Ansari, K. Shaikh, P. Kadu, and N. Rishikesh, "IOT Based Coal Mine Safety Monitoring and Alerting System," *Int. J. Sci. Res. Sci. Eng. Technol*, vol. 8,

- pp. 404–410, 2021.
3. M. Shakunthala, C. Raveena, B. Saravanan, S. S. Kumar, and R. S. Saran, “IoT Based Coal Mine Safety Monitoring and Controlling,” *Ann. Rom. Soc. Cell Biol.*, pp. 12381–12387, 2021.
 4. S. R. Deokar and J. S. Wakode, “Coal mine safety monitoring and alerting system,” *Int. Res. J. Eng. Technol.*, vol. 4, no. 3, pp. 2146–2149, 2017.
 5. M. Rudrawar, S. Sharma, M. Thakur, and V. Kadam, “Coal mine safety monitoring and alerting system with smart helmet,” in *ITM Web of Conferences*, 2022, vol. 44, p. 1005.
 6. M. Ndoh and G. Y. Delisle, “Underground mines wireless propagation modeling,” in *IEEE 60th Vehicular Technology Conference, 2004. VTC2004-Fall. 2004*, 2004, vol. 5, pp. 3584–3588.
 7. A. Singh, D. Kumar, and J. Hötzel, “IoT Based information and communication system for enhancing underground mines safety and productivity: Genesis, taxonomy and open issues,” *Ad Hoc Networks*, vol. 78, pp. 115–129, 2018.
 8. R. Liang, L. Zhao, and P. Wang, “Performance evaluations of LoRa wireless communication in building environments,” *Sensors*, vol. 20, no. 14, p. 3828, 2020
 9. V. Henriques and R. Malekian, “Mine safety system using wireless sensor network,” *IEEE access*, vol. 4, pp. 3511–3521, 2016.
 10. S. M. Melody and F. H. Johnston, “Coal mine fires and human health: What do we know?,” *Int. J. Coal Geol.*, vol. 152, pp. 1–14, 2015.
 11. W. Chen and X. Wang, “Coal mine safety intelligent monitoring based on wireless sensor network,” *IEEE Sens. J.*, vol. 21, no. 22, pp. 25465–25471, 2020.
 12. K. Anitha and T. Seshagiri, “Implementation of wireless sensor in coal mine safety system using ZigBee,” *Int. Res. J. Eng. Tech.*, vol. 6, pp. 1467–1472, 2019.
 13. P. S. CHITHRA, P. J. D. ROSITA, and E. C. E. AP, “Multiple Hazard Detection In Mine Using Embedded System