

# Strengthening of the railroad track for high-speed traffic on the Bukhara-Misken section

*Abduhamit Abdujabarov*<sup>1</sup>, *Pardaboy Begmatov*<sup>1</sup>, *Mashkhurbek Mekhmonov*<sup>1\*</sup>, and *Farkhod Eshonov*<sup>1</sup>

<sup>1</sup>Tashkent State Transport University, Tashkent, Uzbekistan

**Abstract.** In the article the work of ballast prism and subgrade is considered, on the basis of analysis two-layer reinforcement from geotextile is offered, also strengthening by water-soluble polymer in conditions of sandy zone on high-speed sections of railroads is suggested. The principle of stationarity of the total potential energy of deformable Lagrangian systems is used to determine the stress-strain state of the earth bed. The dependences between the components of stress and strain tensors characterizing specific models of the medium have been established, and an elastic ground medium with no residual deformation from external load has been considered. And also offer designs of sleepers with concave surface, which will increase the service life and ensure the reliability of its operation on horizontal and vertical curves of railroads. A new fluoroplastic under-rail gasket, which does not change its characteristics during 5 years, contacting with the base of the rail, flat inner support surface, contacting with the sleeper, reduces load vibration from the rolling stock on the sections of high-speed traffic is offered.

## 1 Introduction

To ensure high-speed traffic in sandy soils with a relatively weak base of embankments and changes in its height, it is necessary to additionally strengthen the subgrade, ballast prism, gaskets and culverts in embankments because it is known that there are additional vibrations such as seismic.

During the movement of rolling stock, the track structure and subgrade experience harmonic vibrations with a frequency that depends on the speed of movement. Similar loads are experienced by the road structure in an earthquake, differing in the force of impact and frequency of vibration.

The main stage of stability calculation of railway embankments is the determination of stresses and intensity of tangential stresses and identification of surfaces where these values reach the limit values and identification of cracks in the embankment body during the operation of the road. Using the methods of mechanics of deformable solid bodies we study the stress-strain state of a multilayer railway embankment made of soil layers with different physical and mechanical properties and different slope steepness. For calculation we use the finite element method (FEM), the advantages of which are: the simplicity of obtaining

---

\* Corresponding author: [m.mehmonov90@mail.ru](mailto:m.mehmonov90@mail.ru)

systems of solving equations, the possibility of densifying the mesh of elements in places of high gradients of the investigated structure and setting any boundary conditions, as well as taking into account inhomogeneous deformation and density properties of the material - all this is easily programmed in algorithmic languages [1, 2, 3].

## 2 Materials and Methods

To determine the stressed and deformed state of the earth bed, the principle of stationarity of the total potential energy of deformable systems Lagrange is used, the mechanical interpretation of which is that if the system is in equilibrium, the sum of the works of all internal and external forces is equal to zero, i.e. rigidly fixed:

$$u+v=0; \tag{1}$$

Let us proceed to the description of the algorithm determined stress-strain state of plane elasticity problems. Based on the finite element method (FEM), the studied computational domain is partitioned into high-order quadrangular quadratic elements. Within each element, the material is homogeneous. The ratio defining the form functions are of the form form:

$$\begin{aligned} h_1 &= -0,25(-\xi)(1+q)(\xi-q+1), \\ h_2 &= 0,5(1-q^2)(1-\xi), \\ h_3 &= -0,25(1-\xi)(1-q)(\xi+q+1), \\ h_4 &= 0,5(1-\xi)(1-q), \\ h_5 &= 0,25(1+\xi)(1-q)(\xi-q-1), \\ h_6 &= 0,5(1-q^2)(1+\xi), \\ h_7 &= 0,25(1+\xi)(1+q)(\xi+q-1), \\ h_8 &= 0,5(1-\xi^2)(1+q). \end{aligned} \tag{2}$$

Displacement functions within the element are determined by the formula:

$$U = \sum_{i=1}^q h_i u_i; \quad V = \sum_{i=1}^q h_i v_i, \tag{3}$$

where  $U, V$  – repositioning of any point;

$u_i v_i - 1,8$  1.8 q-node bias.

Deformations within the element are determined by differentiating the expression (3)

$$\varepsilon x = \frac{du}{dx}, \quad \varepsilon y = \frac{dv}{dy}, \quad \nu_{xy} = \frac{dv}{dy} + \frac{du}{dx}; \tag{4}$$

or  $\{\varepsilon\} = [B]\{\sigma\}; \quad \{\sigma\} = \{u_1 \nu_1 \ u_2 \nu_2 \ \dots \ u_8 \nu_8;$

$$B = \begin{bmatrix} \frac{dh_1}{dx} & 0 & \frac{dh_2}{dx} & 0 & \dots & \dots & \frac{dh_8}{dx} \\ 0 & \frac{dh_1}{dy} & 0 & \frac{dh_2}{dy} & 0 & \dots & \frac{dh_8}{dy} \\ \frac{dh_1}{dy} & \frac{dh_1}{dx} & \frac{dh_2}{dy} & \frac{dh_2}{dx} & \dots & \dots & \frac{dh_8}{dy} \frac{dh_8}{dx} \end{bmatrix} \tag{5}$$

The stiffness matrix of the element is calculated using a double integral:

$$[K^c] = t \int_{-1}^1 \int_{-1}^1 [B]^T [D] [B] \det [J] d \varphi d \varepsilon; \tag{6}$$

The integral (6) after applying the Gauss-Lejandre quadrature has the form:

$$[K^c] = t \sum_{i=1}^n \sum_{j=1}^n N_i H_j [B]^T [D] [B] |\det [J]|, \tag{7}$$

where  $H_i, H_j$  ( $i, j = 1, 2, 3$ ) – weighting factors;

$n$  – number of integration points along the direction  $\xi$  and  $q$ .

The stiffness matrix of systems  $[K]$  is formed by summing over all  $m$  elements of the stiffness matrix

$$[K] = \sum_{i=1}^m [K_i^e]; \tag{8}$$

If the stiffness matrix of the system  $[K]$  is known, the basic system of algebraic equations is easily obtained:

$$[K] = \{M\} = \{E\}; \tag{9}$$

where  $M, F$  – are the displacement and force vectors of all nodes, respectively. The system of algebraic equations is solved by the Gaussian method of sequential elimination.

Based on the outlined algorithm, a program was compiled and calculations were performed to find out the effect of high-speed traffic on the stress state of the subgrade.

Theoretical and experimental studies of the state of the earth bed with height up to  $H=10\text{m}$ , consisting of different soils, allowed to determine the zone of increased stress, which is created during high-speed traffic from the rolling stock. Theoretical and experimental studies of the state of the earth bed with height up to  $H=10\text{m}$ , consisting of different soils, allowed to determine the zone of increased stress, which is created during high-speed traffic from the rolling stock.

The obtained scheme of calculation of the earth bed at high-speed train traffic will allow to determine that the most vulnerable is the embankment in the upper part of the limit - 4 m [4, 5] - Fig. 1, 2. The results of these calculations lead to the need to reinforce the sandy soil in this zone, which experiences the highest stresses. The results of these calculations lead to the need to reinforce the sandy soil in this zone, which experiences the highest stresses. Spraying bituminous emulsion with hot water on road slopes, which is not difficult to obtain in desert conditions. Treatment of slopes and base should be carried out up to the fence walls - this will save from sandstorms during high-speed train traffic and reduce the degree of sand drifting into the ballast prism, which will ensure the reliability of its operation and increase the time between repairs. The stability of such an earth bed is ensured even in an earthquake up to 8 points [6, 7], because during high-speed traffic the railroad track experiences amplitude-frequency vibrations as in an earthquake of 6 points of seismic activity. The reinforcement layer of  $1\div 2$  cm is created depending on the combination of the wind rose and the direction of the road route.

The reinforcing layer can be made by water-soluble polymer AKS-1, AKS -2, K-4, obtained in the Institute of Chemistry of Inorganic Substances of the Academy of Sciences of Uzbekistan, under the leadership of Academician Akhmedov K.S. Spraying of polymer solution of  $1\%\div 5\%$  concentration creates a  $1\div 2$  cm layer of reinforced sand, which fully protects from wind air flows and aerodynamic disturbances of air flow when passing a high-speed train. As the RoW is fenced with a mesh fence, the reinforced layer will not be disturbed from accidental impacts: people and wandering animals. The proposed water-soluble polymer is a product of the industry of Uzbekistan, has a low cost and has long been successfully used to strengthen wells in geology. When rainfall occurs, the dense layer becomes soft again, which does not prevent vegetation from growing - this will further strengthen the sand layer.

For long-term operation, gaskets made of fluoroplastic - F-4 are proposed, which are implemented at the pilot site and their reliable operation does not change during 5 years of observation [8, 9, 10]. Under-rail gasket containing a base with a flat bearing surface in contact with the rail base, a flat inner bearing surface in contact with the sleeper, characterized by the fact that the gasket made of fluoroplastic F-4 in the form of a rectangular plate with protrusions, provides resistance to longitudinal and transverse movements of the rail during operation, long service life in all weather conditions and reduces vibration loads from rolling stock on sections of high-speed traffic.

Concave sleeper structures have better adhesion to the ballast prism, reduced stresses on the subgrade and increased resistance to horizontal loads [11, 12, 13, 14]. The proposed design of reinforced concrete sleeper will allow to increase the service life and ensure the reliability of its operation on horizontal and vertical curves of the road route with an increase in the time between repairs up to 20%.

Studies of the analysis of the operation analysis of the railroad bed shows that on different sections the rigidity of the track changes significantly, which adversely affects the strength characteristics of the road and the running part of the rolling stock. It is known that the

stiffness of the track top structure is affected by the construction of the earth bed, change of soils, density of their composition and change of their humidity, which depends on atmospheric precipitation [15, 16]. Numerous studies and it is confirmed by the analysis of the operation of the railroad bed, rolling stock, that on different sections significantly changes the rigidity of the track and it adversely affects the strength characteristics of the railroad bed and the running part of the rolling stock [17, 18, 19, 20, 21]. It is known that the stiffness of the track top structure is influenced by the construction of the earth bed, change of soils, their density and especially their moisture content. It follows that the most acceptable conditions for the railroad will be the creation of the earth bed construction with the smallest changes in the moisture content of the earth bed soil and the base, which in parallel will ensure the density of soils without changing the angle of internal friction. In this case, the necessary reduction in the stiffness of the track structure is provided uniformly along the entire length of the road, regardless of changes in the properties of the subgrade soils and its construction.

### 3 Results and Discussions

Analysis of the results of theoretical studies of track stiffness, as well as experimental studies on different sections of the Uzbekistan railroad, which are located in different climatic zones with unequal degree of settlement and filtration coefficient of subgrade soils create conditions for sharp changes in track stiffness. All these factors of changing the stiffness of the track allowed us to propose a cross-section of the subgrade using geotextile [22, 23, 24, 25]. This allows a more uniform distribution of loads in the track structure and subgrade, as well as a significant reduction in the influence of atmospheric precipitation on the railroad track - Fig. 3.

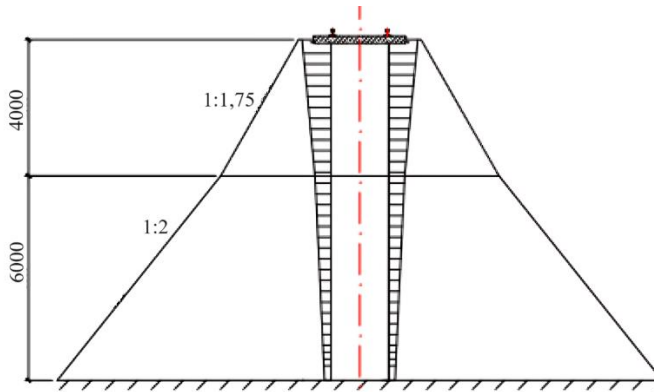

**Fig. 1.** Stress- $\sigma_y$  epuples along axes I-II, obtained in sandy soils of 0,1-0,45 kg/sm<sup>2</sup>.

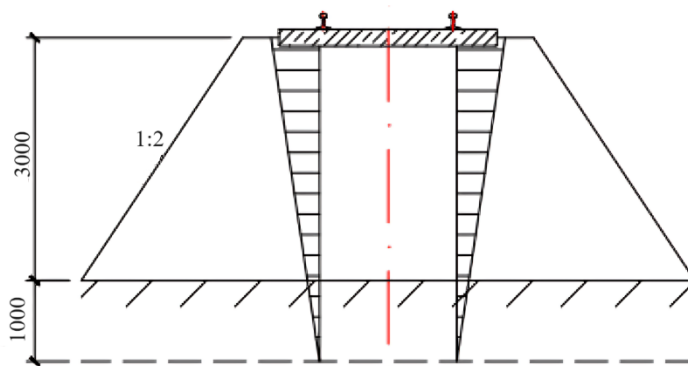

**Fig. 2.** Stress– $\sigma_y$  epuples along axes I-II, with sandy soils at H=3m. i.e. the stress is transferred to the foundation soil at a depth of  $h=1$  m, i.e. the soil foundation should be strengthened.

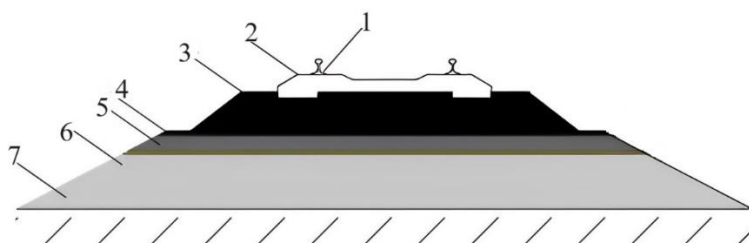
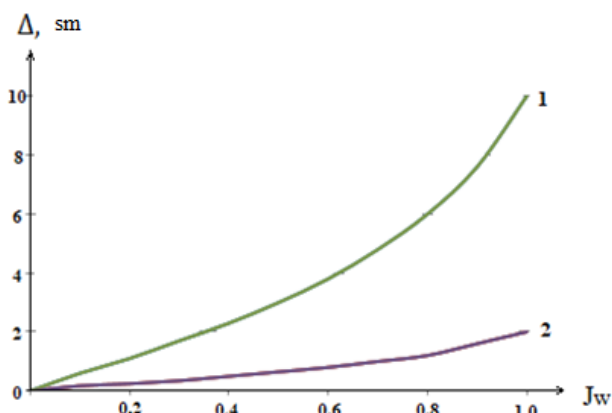

**Fig. 3.** Cross-sectional profile of the subgrade made of sand reinforced with geotextile and water-soluble polymer.

1. Gasket F-4.
2. Railway sleeper with concave support part.
3. Ballast prism.
4. Layer of coarse sand,  $h=5$  cm.
5. Geotextile.
6. AKS-2 water-soluble polymer,  $h=3$  cm.
7. The earth bed.

Along the length of the road alignment, soils and embankment heights vary, creating a length of unevenness as the stiffness of the road changes with changes in soil moisture, which contributes to varying amounts of soil settlement.

For clarity, the values of earth bed settlement are obtained, which gives and the settlement of the ballast prism depending on the height of the earth bed and the degree of soil moisture - Figs. 4,5.



**Fig.4.** The value of earth bed settlement from the degree of soil moisture -  $J_w$  at embankment height  $H=10m$ : 1 with geotextile lining. 2-without geotextile lining.

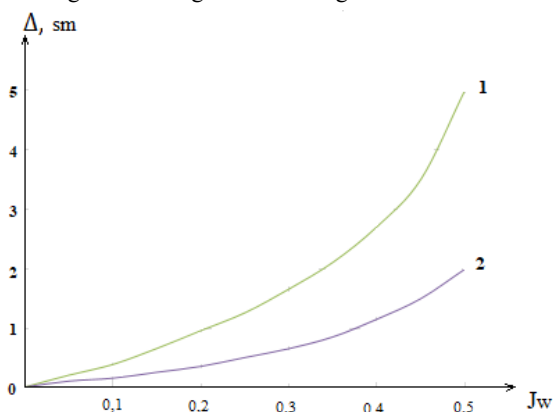

**Fig.5.** The value of earth bed settlement from the degree of soil moisture -  $J_w$  at embankment height  $H=10 m$  and embankment widening by 1 m and slope steepness 1:3: 1 with geotextile lining. 2-without geotextile lining.

Based on theoretical calculations and experimental studies, it can be concluded that increasing the slope gradient and increasing the width of the main site leads to a decrease in the stresses in the soil of the earth bed.

## 4 Conclusions

1. The geotextile pad reduces moisture in the subgrade soil from atmospheric deposition and secures the subgrade with a water-soluble polymer.
2. Geotextile lining and reinforcement of the subgrade soil reduces amplitude-frequency impacts from high-speed traffic to 2 points.
3. Increasing the main area of the subgrade by 1 m and increasing the slope gradient reduces the amplitude-frequency impact from high-speed traffic by 1 point.

## References

1. A. Abdujabarov, et .al., E3S Web of Conferences, **401**, 03003 (2023)  
<https://doi.org/10.1051/e3sconf/202340103003>

2. M. Mekhmonov, Sh. Makhamadjonov. E3S Web of Conferences, **401**, 05032 (2023), <https://doi.org/10.1051/e3sconf/202340105032>
3. M. Mekhmonov, A. Uralov. E3S Web of Conferences, **401**, 02040 (2023), <https://doi.org/10.1051/e3sconf/202340102040>
4. A. Abdujabarov, et.al., E3S Web of Conferences, **401**, 02042 (2023), <https://doi.org/10.1051/e3sconf/202340102042>
5. A.Kh., Abdujabarov M.Kh. Mekhmonovm, AIP Conference Proceedings **2432**, 030045 (2022); <https://doi.org/10.1063/5.0093489>
6. A.H. Abdujabarov, P.A. Begmatov, F.F. Eshonov, M.H. Mekhmonov, M.K. Khamidovm, E3S Web of Conferences **264** (2021), <https://doi.org/10.1051/e3sconf/202126402019>
7. Abdujabarov A.Kh., Mekhmonov M.Kh., Eshonov F.F.m AIP Conference Proceedings **2432**, 030003 (2022); <https://doi.org/10.1063/5.0089531>
8. Muzaffarova, M., Mirakhmedov, M. (2021). E3S Web Conf. In International Scientific Conference "Construction Mechanics, Hydraulics and Water Resources Engineering"(CONMECHYDRO-2021) (Vol. **264**).
9. Muzaffarova, Mauzhuda. Transport Problems: an International Scientific Journal **17.4** (2022).
10. Miraxmedov, M., Khudoyorov, A., Abdullaev, K., Muzaffarova, M. (2022, June). AIP Conference Proceedings (Vol. **2432**, No. 1). AIP Publishing.
11. Umarov K. et al. E3S Web of Conferences. 2023. **401**. 03018. DOI: <https://doi.org/10.1051/e3sconf/202340103018>
12. Khalfin G. A. et al. E3S Web of Conferences., 2023. **401**. 02050. DOI: <https://doi.org/10.1051/e3sconf/202340102050>
13. Shayakhmetov S. et al. E3S Web of Conferences., 2023. **401**. 01077. DOI: DOI: <https://doi.org/10.1051/e3sconf/202340101077>
14. Shayakhmetov S. et al. E3S Web of Conferences., 2023. **401**. 01083. DOI: <https://doi.org/10.1051/e3sconf/202340101083>
15. Lesov K.S., Kenjaliyev M.K., Mavlanov A.Kh. and Tadjibaev Sh.A., E3S Web Conf. **264** 02011 (2021). DOI: [10.1051/e3sconf/202126402011](https://doi.org/10.1051/e3sconf/202126402011)
16. Lesov K.S. and Kenjaliyev M.K. AIP Conference Proceedings. Vol. **2432**. No. 1. AIP Publishing LLC, 2022. p. 030026
17. Konshin G.G. A new method for determining dynamic stresses. "The way and the way economy", 2000 No. **9**. pp. 30-34.
18. Pevsner V.O. Deformability and stability of the path // Path and track economy. 2005. No. **2**. pp. 23-26.
19. Lanis A. L. On the issue of strengthening the earthwork of railways by reinforcement / A. L. Lanis // Proceedings of the international conference "The role of track management in the infrastructure of railway transport: Saransk, GUPRM "Red October" PTKB CP JSC "Russian Railways", 2012. – pp. 132-137.
20. Lanis A. L. Restoration of operational reliability of the roadbed / A. L. Lanis, S. A. Ovchinnikov // Materials of the international conference "Modernization and scientific research in the transport complex". – Perm: PNRPU Publishing House, 2012. – pp. 189-195.

21. Kolos A.F. Antidynamic stabilization of the railway roadbed by cementation of the soils of the main site: diss. knad. technical sciences/ A.F. Kolos; PGUPS. – St. Petersburg, 2000. -163 p.
22. Bogomolov A.N. Evaluation of the stress-strain state, the magnitude of the stability coefficient and the forces of landslide pressure in a homogeneous isotropic slope in order to control landslide processes / A.N. Bogomolov et al. // Vestn. VolgGASU. Ser.: Page and archit. – Volgograd: VolgGASU, 2008. – Issue 10(29). – pp. 74-80.
23. Ashpiz E.S. Evaluation of deformations of the main platform of the roadbed according to diagnostic complexes / E.S. Ashpiz // Modern problems of design, construction and operation of a railway track: tr. IX Sci.-tech. conf. From the international. participation. – M.: MIIT, 2012, – pp. 59-63.
24. Neidhart, T. Dynamic Stability of Railway Tracks – DyStaFiT, and Innovation in Testing: proc. from Georail / T. Neidhart, G. Shultz. – Paris, 2011. – p. 335-346.
25. Reinforced concrete sleepers for a rail track / A. F. Zolotarsky, B.A. Evdokimov, N.M. Isaev, L.G. Krysanov, V.V. Serebrennikov, V.F. Fedulov. Edited by A.F. Zolotarsky. – M.: Transport, 1980. – 270 p.